

# Safari

## ORIGAMI

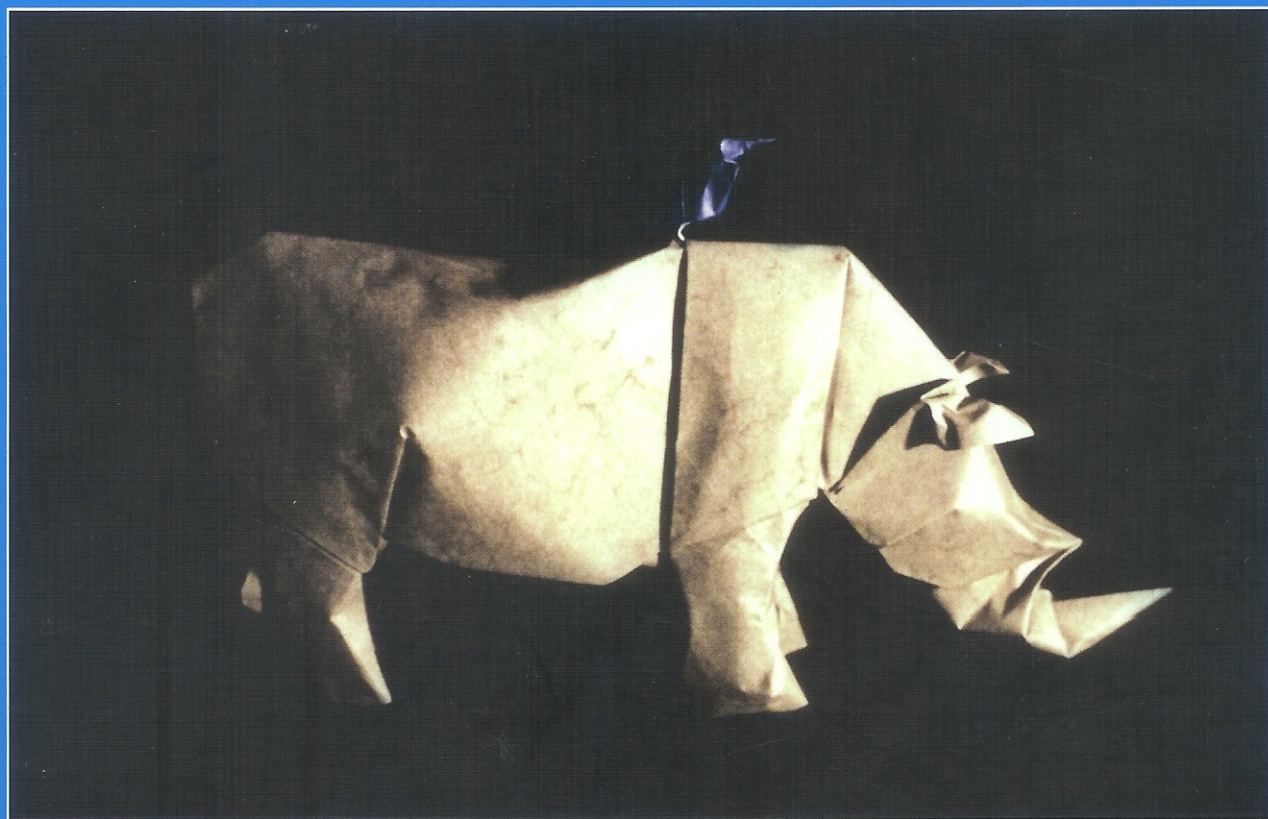

Lionel Albertino

Verlag Die Blechschachtel

## A ma femme, ma fille, mon fils

Originaltitel: Safari Origami, Albertino, Lionel

Alle Rechte bei © Verlag Die Blechschachtel. März 2002. Erstauflage erschien im Selbstverlag des Autors.  
Pfinztalstraße 94, D-76227 Karlsruhe Tel.: (0721) 4 40 20

Druck und Bindung: Druckerei Grässer, Karlsruhe Tel.: (0721) 61 50 50

Die Verwendung der Texte und Bilder, auch auszugsweise ist ohne Zustimmung des Verlags  
urheberrechtswidrig und strafbar. Dies gilt auch für Vervielfältigungen, Übersetzungen,  
Microverfilmung und Verarbeitung mit elektronischen Medien.

No part of this book may be copied or reproduced in any manner without written permission  
of the publishing house © Verlag Die Blechschachtel.

Printed in Germany

ISBN 3-9807526-9-0

Weiterer Titel im Verlag Die Blechschachtel :

Peter Budai, "Papierspielzeuge" ISBN 6-00-006703-5 und ISBN 3-9807526-3-1

Peter Budai, "Papierfalten grenzenlos" ISBN 3-0000-6233-5 und ISBN 3-9807526-4-x

Eduard Maier und Evelyn Binzinger, Märchenhaftes Origami. Origamimodelle von 71 Autoren aus aller Welt. Ca 700  
Seiten. ISBN 3-9807526-2-3. Erscheinungsdatum Juli 2002

Eduard Maier:

Der Papiertiger in der Blechschachtel und der faltende Poet Nr 1 ISBN 3-9807526-0-7

Der Papiertiger in der Blechschachtel und der faltende Poet Nr 2 Magazin für geistige und haptische Erholung.

ISBN 3-9807526-0-7 Erscheinungsdatum September 2002

Marc Kirschenbaum. Paper in Harmony, ISBN 3-9807526-1-5 DM 58.- / 29,65 Euros

# Safari

## ORIGAMI

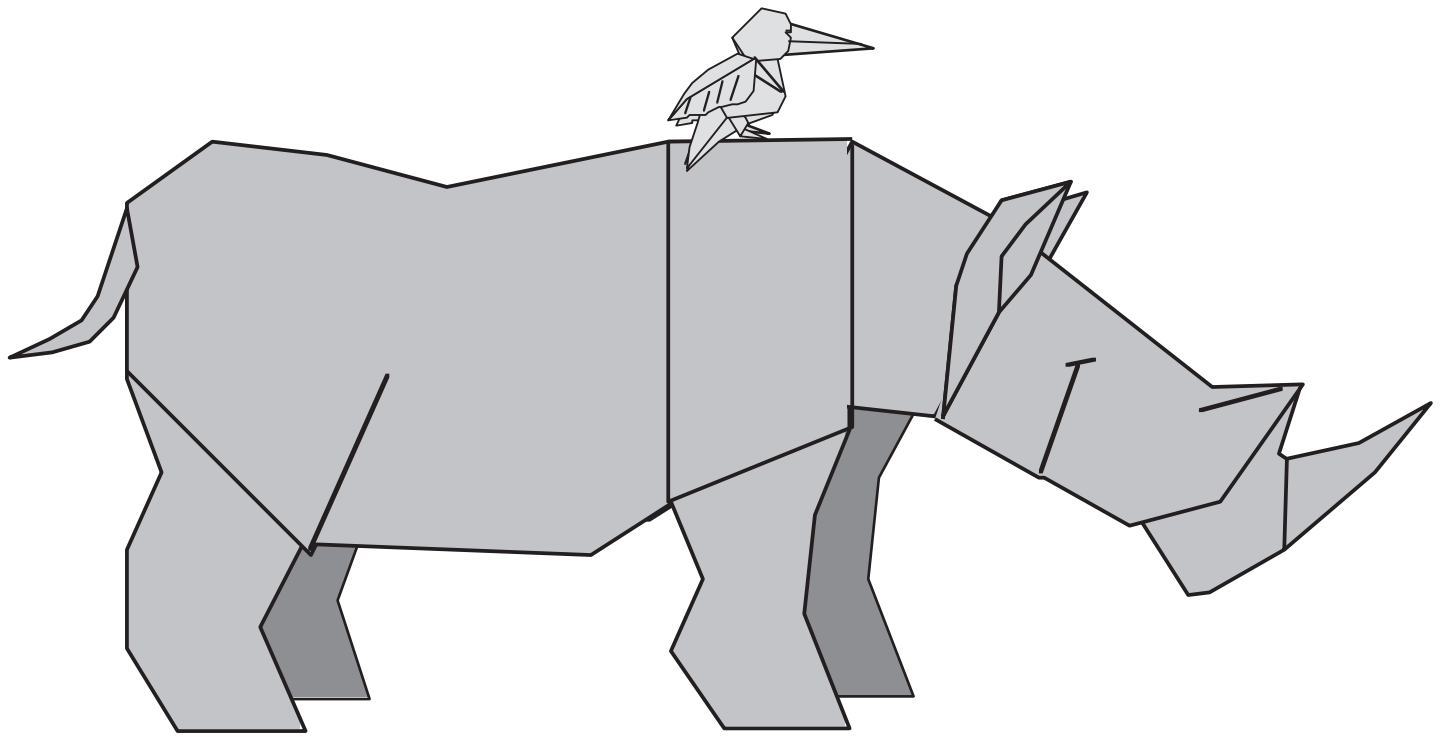

**Lionel Albertino**

ISBN 3-9807526-9-0

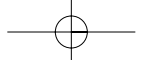

# SOMMAIRE

A propos de la seconde édition..... page 6  
 Avant propos..... page 8  
 Explications des symboles..... page 9  
 Plis de bases..... page 12  
 Modèles..... page 14  
 Table des proportions..... page 152  
 Quelques conseils..... page 153  
 Le Wet folding..... page 155

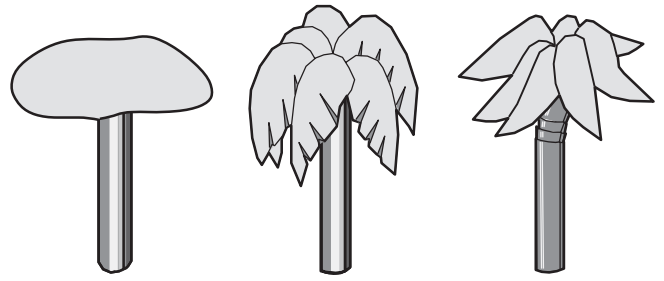

ARBRES  
Page 14 à 18

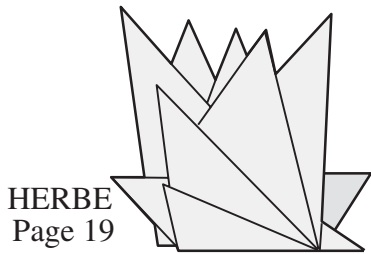

HERBE  
Page 19

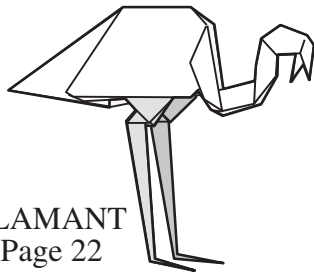

FLAMANT  
Page 22

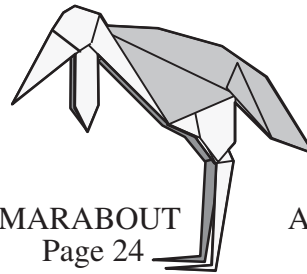

MARABOUT  
Page 24

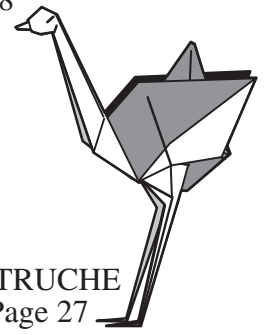

AUTRUCHE  
Page 27

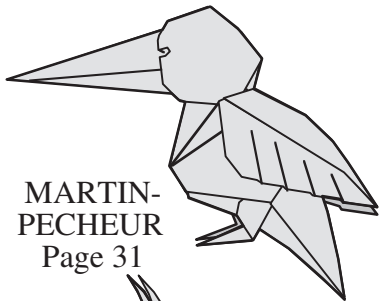

MARTIN-  
PECHEUR  
Page 31

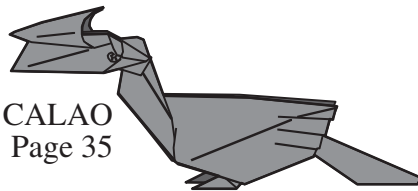

CALAO  
Page 35

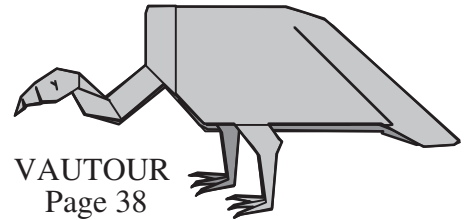

VAUTOUR  
Page 38



GAZELLE  
Page 42

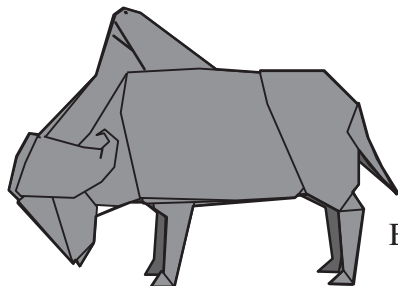

BUFFLE  
Page 47



ZEBRE  
Page 50

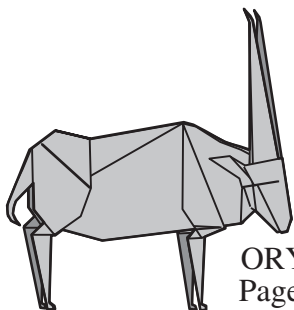

ORYX  
Page 54



GENERUK  
Page 59

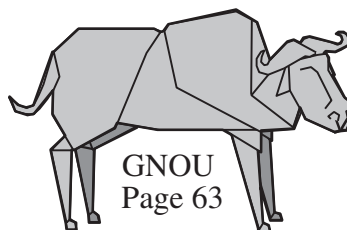

GNOU  
Page 63

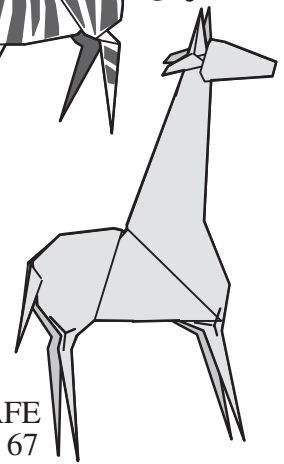

GIRAFE  
Page 67

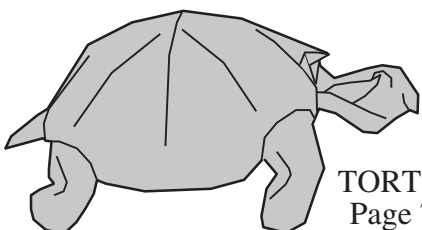

TORTUE  
Page 71

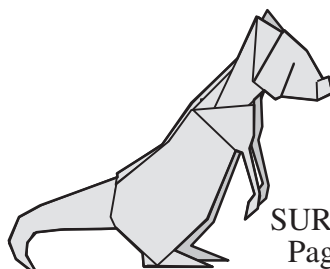

SURICAT  
Page 76



GERBOISE  
Page 79

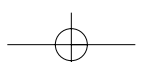

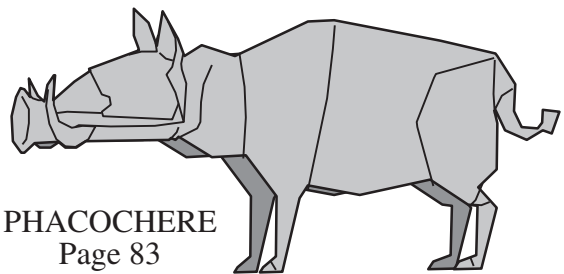
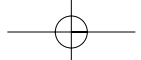

PHACOCHERE  
Page 83

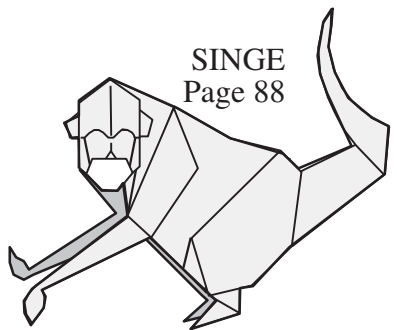

SINGE  
Page 88

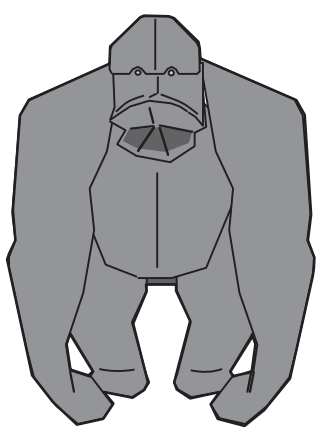

GORILLE  
Page 92

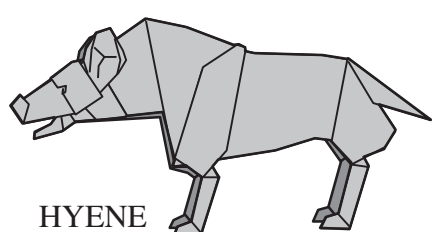

HYENE  
Page 97

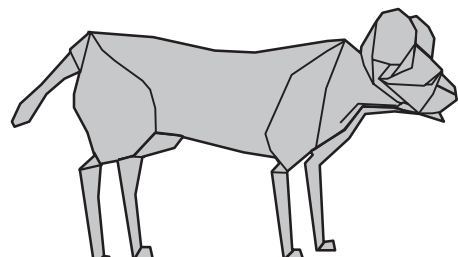

LYCAON  
Page 103

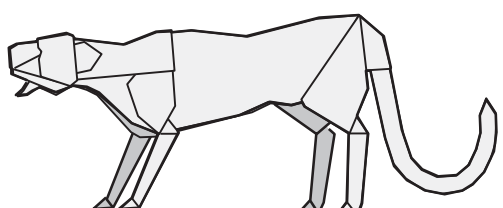

GUEPARD  
Page 108

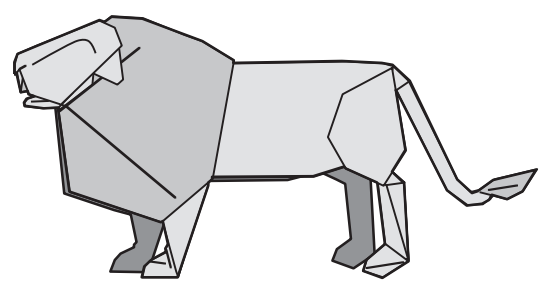

LION  
Page 115

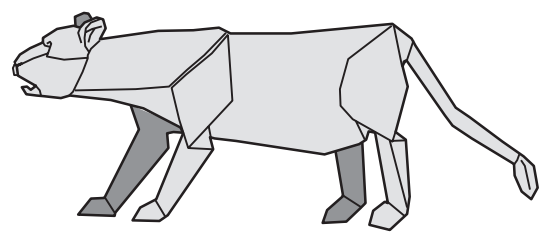

LIONNE  
Page 122

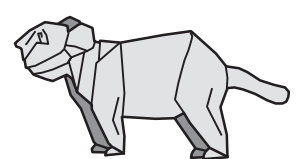

LIONCEAU  
Page 125

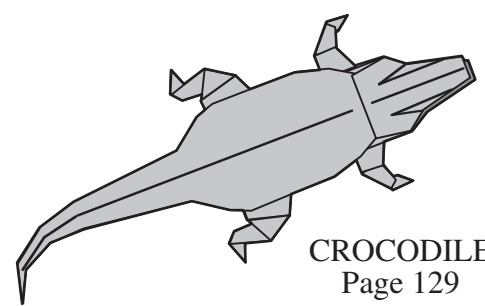

CROCODILE  
Page 129

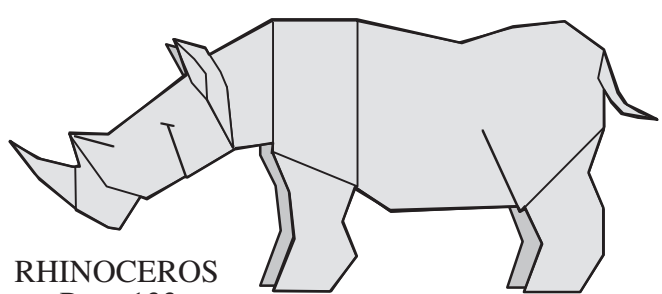

RHINOCEROS  
Page 133

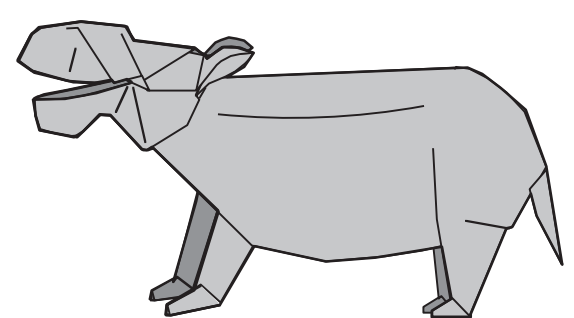

HIPPOPOTAME  
Page 139

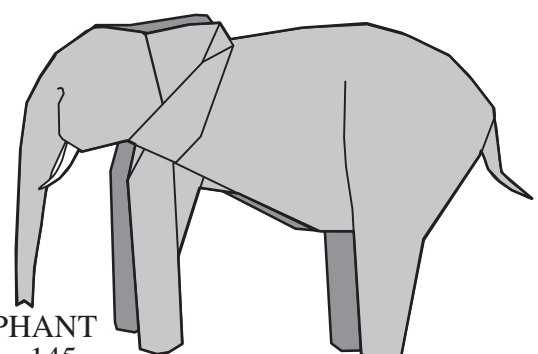

ELEPHANT  
Page 145

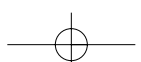
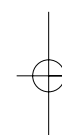
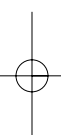



# GAZELLE

Niveau de difficulté : Intermédiaire

Carré couleur : Recto

Format : 28 cm

Modèle terminé : 10 cm

Papier : 80 g

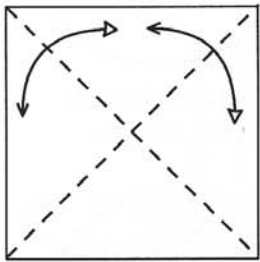

1  
Plier, déplier.

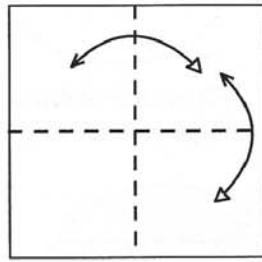

2  
Plier, déplier.

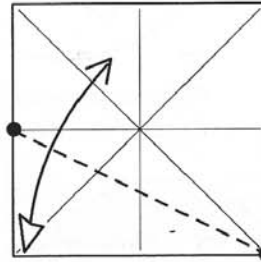

3  
Plier, déplier en utilisant  
les marques des plis.

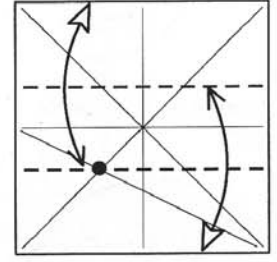

4  
Plier, déplier en vallée à  
l'intersection des plis  
indiqués par le point.

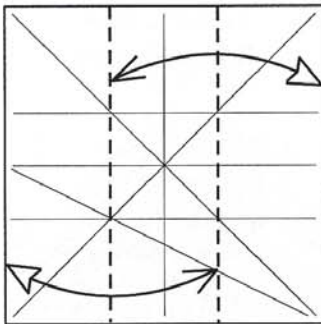

5  
Plier, déplier dans l'autre  
sens.

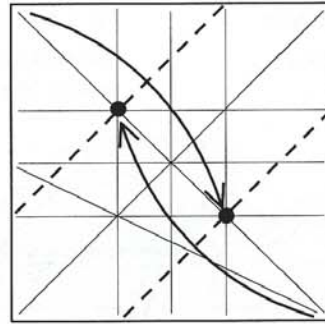

6  
Plier aux intersections.  
Retourner le modèle.

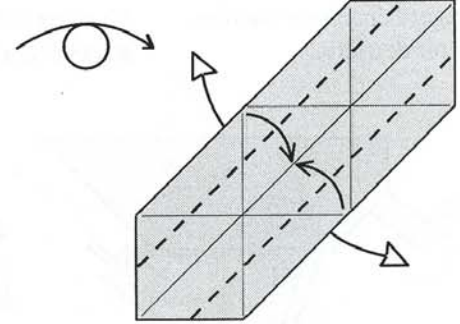

7  
Deux plis vallées.  
Libérer les épaisseurs.

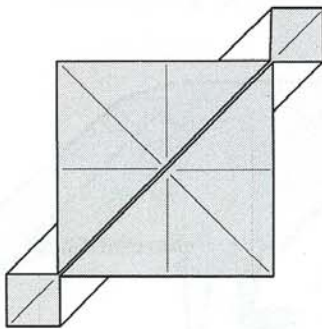

8  
Retourner le modèle.

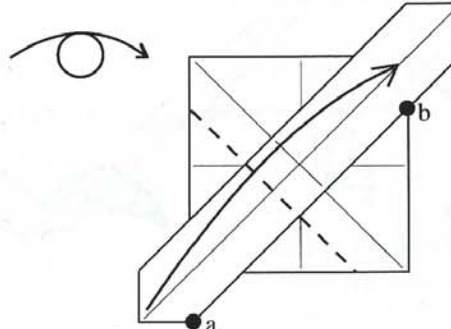

9  
Superposer a sur b.

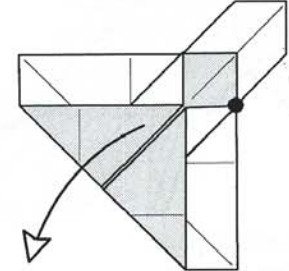

10  
Déplier.

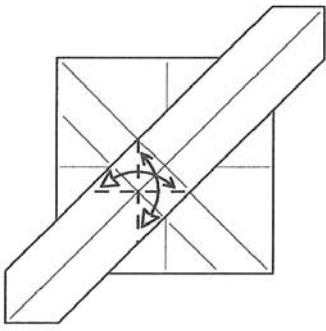

**11**  
Plier, déplier sur la première épaisseur.

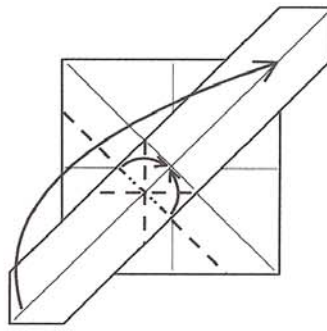

**12**  
Plier la base de la bombe à eau sur la première épaisseur.

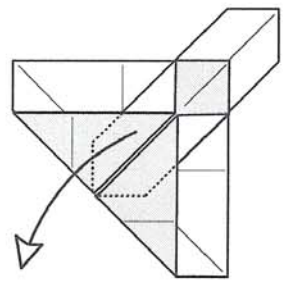

**13**  
Déplier.

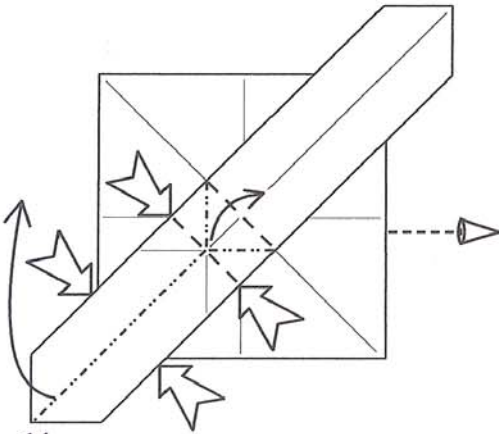

**14**  
Pincer la bande, marquer les plis puis passer à une vue de côté.

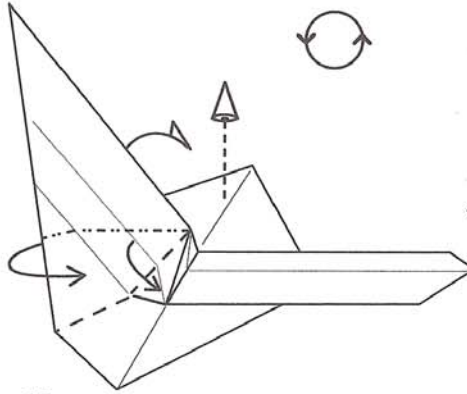

**15**  
Vue intermédiaire du pli 14.  
Pli aplati.  
Rotation du modèle.

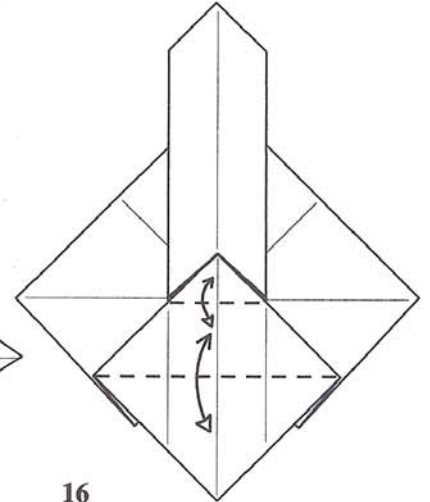

**16**  
Plier, déplier.

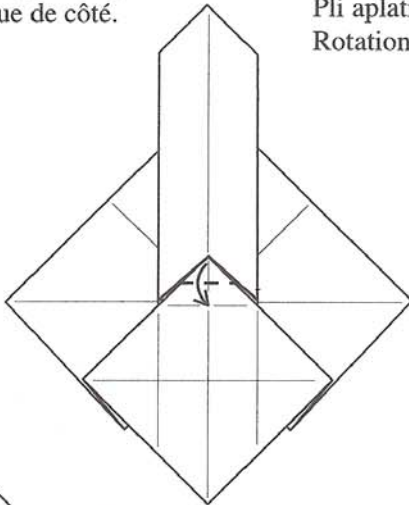

**17**  
Plier en vallée.

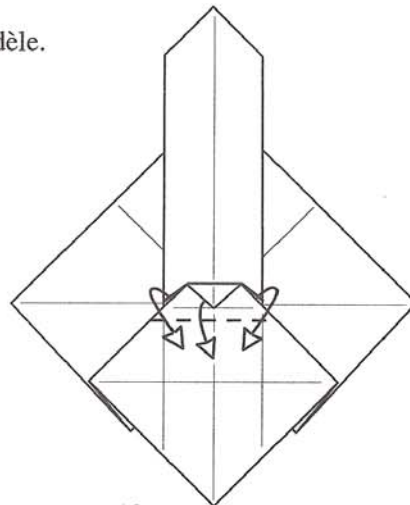

**18**  
Pli étiré.

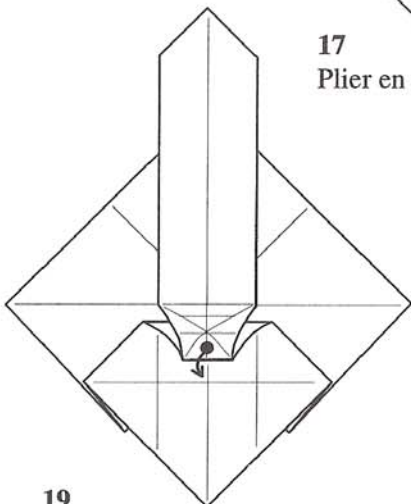

**19**  
Vue intermédiaire du pli étiré.

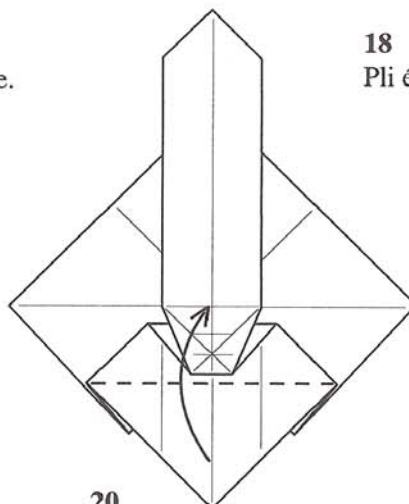

**20**  
Pli vallée.

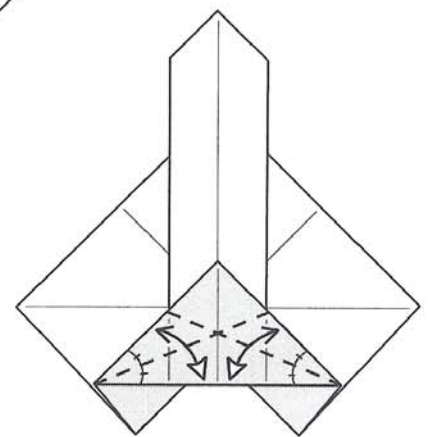

**21**  
Plier, déplier les bissectrices.

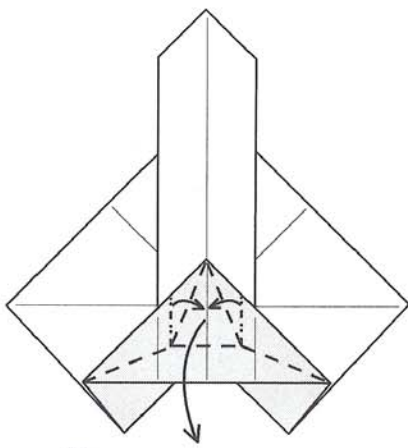

22  
Plis pivots.

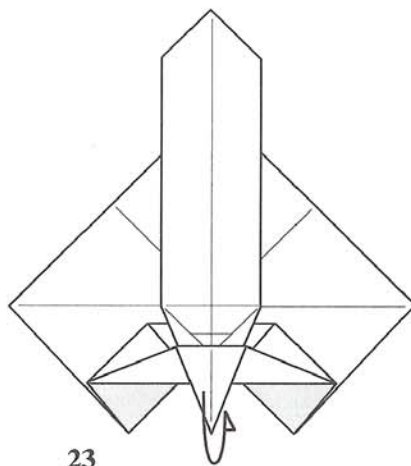

23  
Basculer la queue derrière.

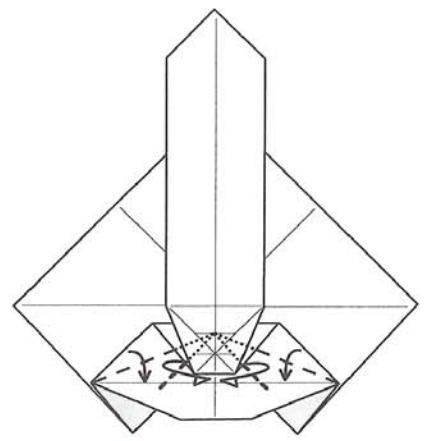

24  
Replis.

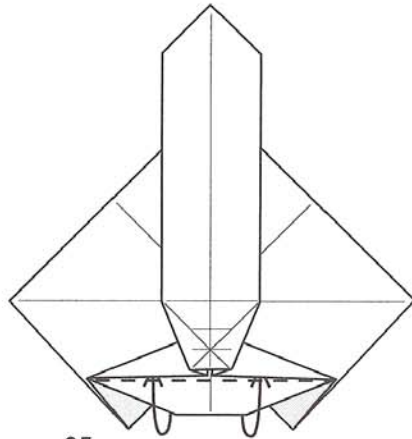

25  
Insérer dans la poche.

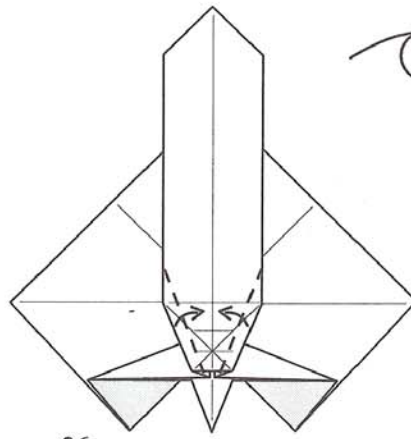

26  
Plis vallées.

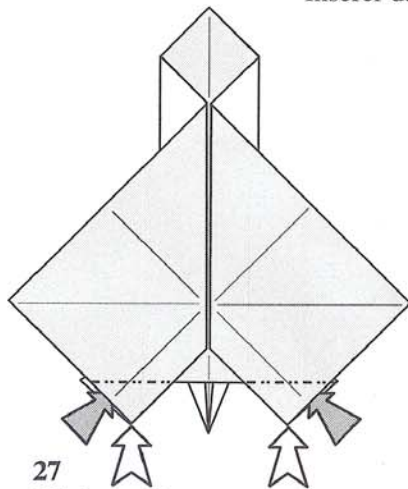

27  
Plis inversés.

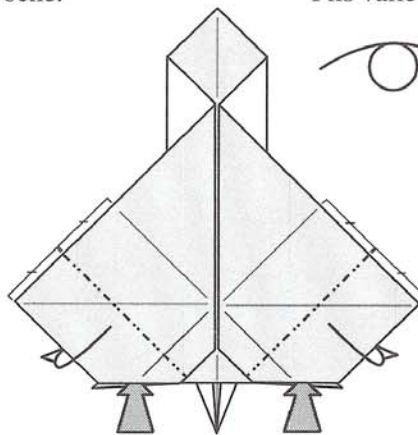

28  
Plier derrière.  
Retourner le modèle.

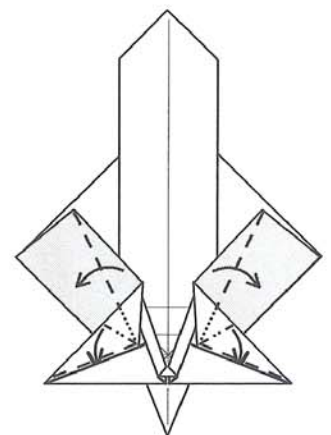

29  
Insérer dans les poches.

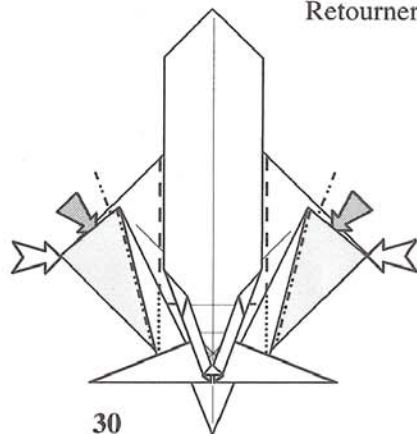

30  
Plis inversés.

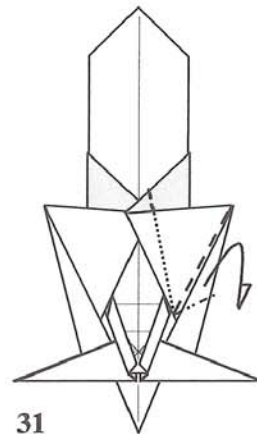

31  
Dégager une patte.



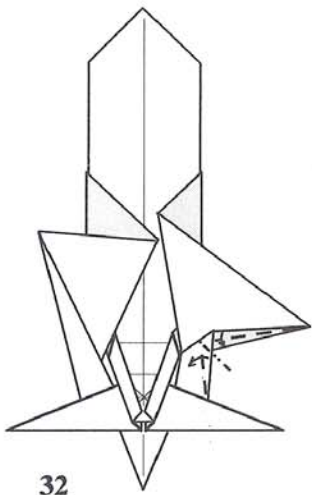

**32**  
Pli aplati.

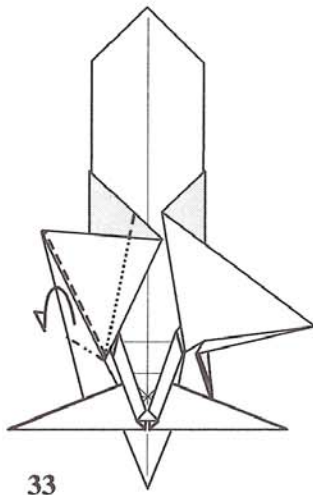

**33**  
Répéter les étapes 31 et 32 à gauche.

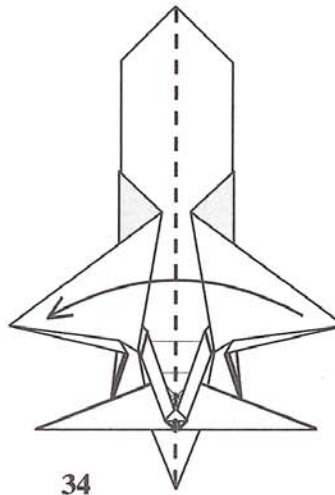

**34**  
Fermer le modèle.

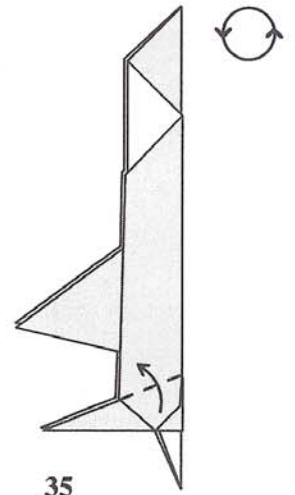

**35**  
Pli vallée.  
Répéter derrière.  
Rotation du modèle.

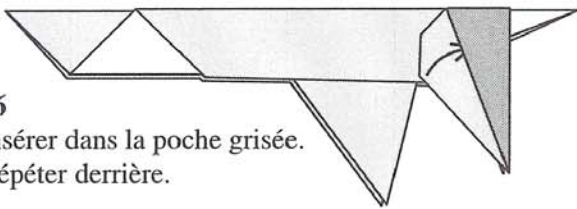

**36**  
Insérer dans la poche grisée.  
Répéter derrière.

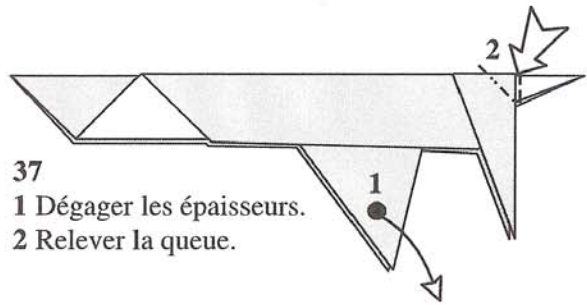

**37**  
1 Dégager les épaisseurs.  
2 Relever la queue.

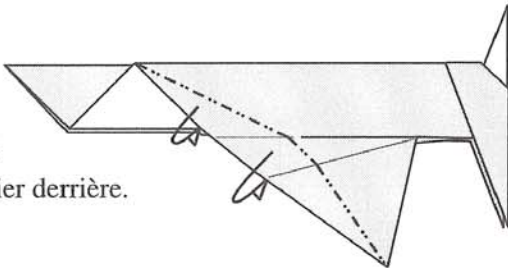

**38**  
Plier derrière.

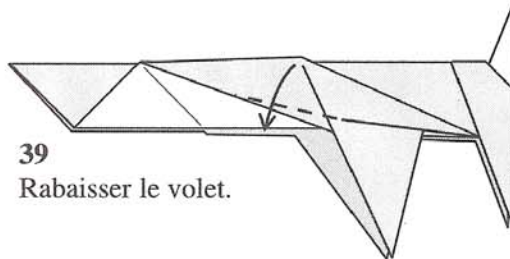

**39**  
Rabaisser le volet.

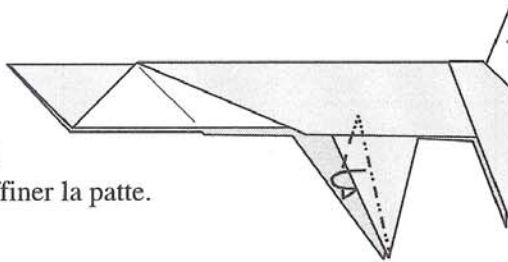

**40**  
Affiner la patte.

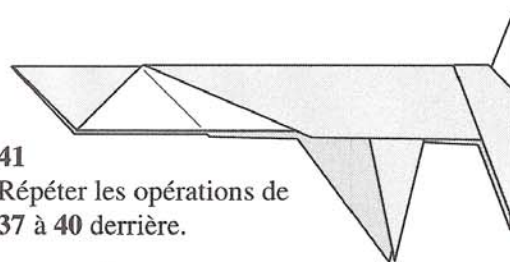

**41**  
Répéter les opérations de 37 à 40 derrière.

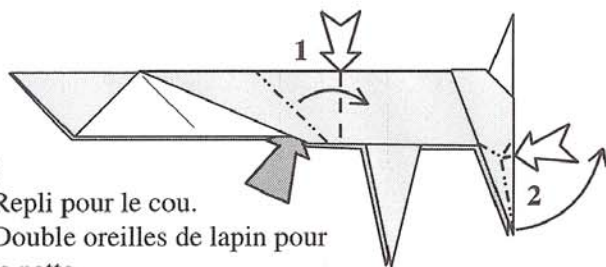

**42**  
1 Repli pour le cou.  
2 Double oreilles de lapin pour la patte.  
Répéter derrière.

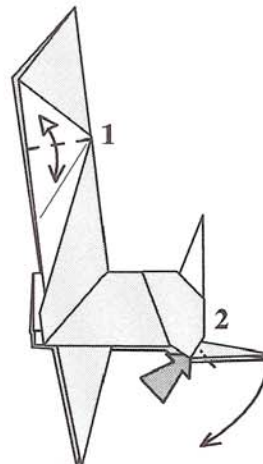

**43**  
1 Marquer le pli pour la tête.  
2 Pli inversé pour former la patte.  
Répéter derrière.

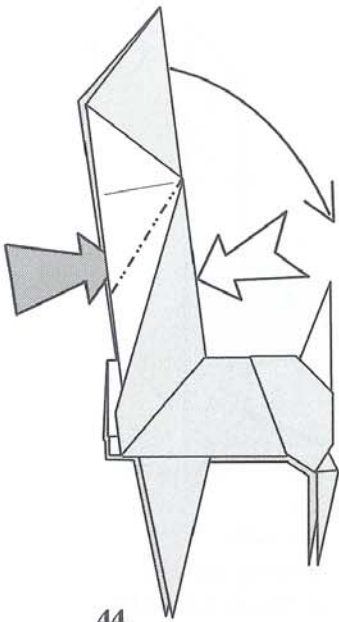

44  
Pli étiré.

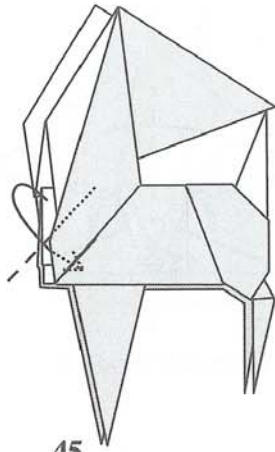

45  
Plier dedans.

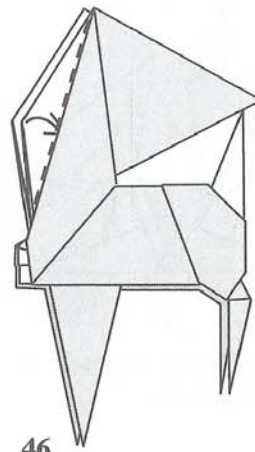

46  
Insérer dans la poche.  
Répéter derrière.

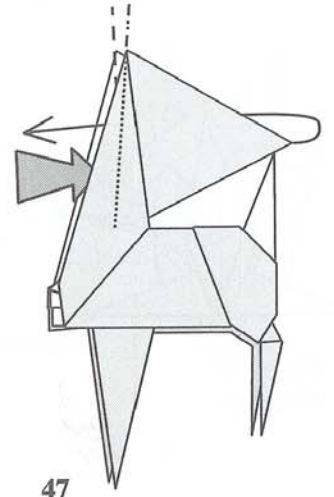

47  
Pli inversé.

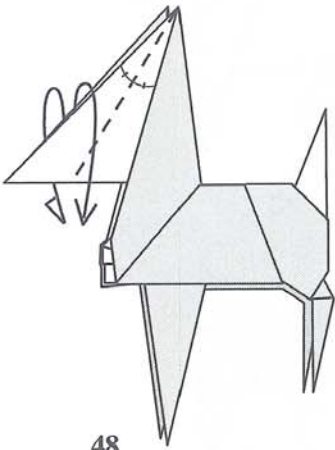

48  
Pli inversé extérieur.

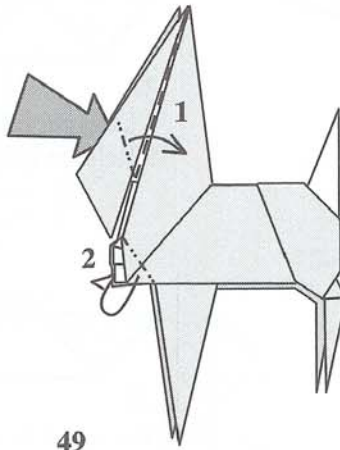

49  
1 Pli pivot pour la tête et les cornes.  
2 Plier à l'intérieur pour le thorax.  
Répéter derrière.

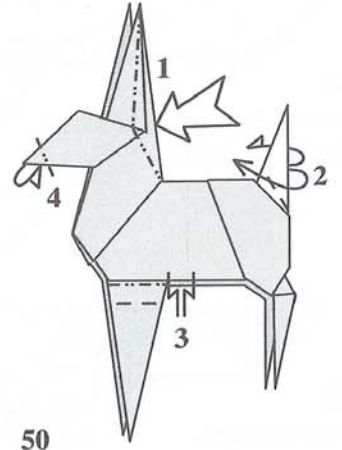

50  
1 Pincer les cornes.  
2 Pli inversé pour la queue.  
3 Repli pour les pattes.  
4 Pli inversé pour le museau.  
Répéter derrière.

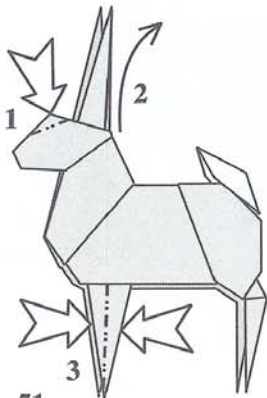

51  
1 Enfoncer le sommet de la tête.  
2 Courber les cornes.  
3 Affiner les pattes.  
Répéter derrière.

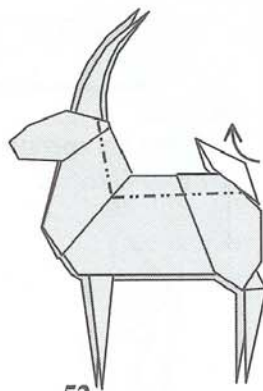

52  
Modelage final.

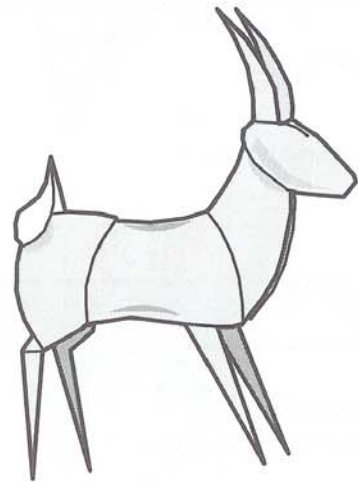

53  
GAZELLE TERMINEE.

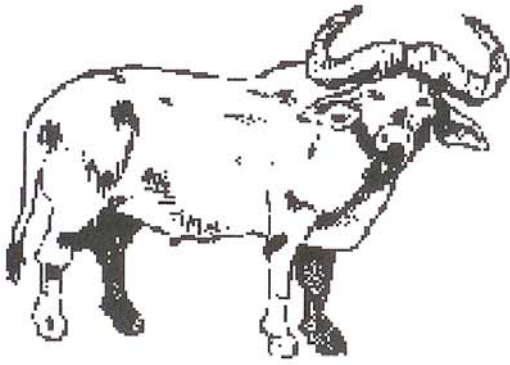

# BUFFLE

**Niveau de difficulté :** Intermédiaire.

**Carré couleur :** Recto

**Format :** 30 cm

**Modèle terminé :** 12 cm

**Papier :** 80 g

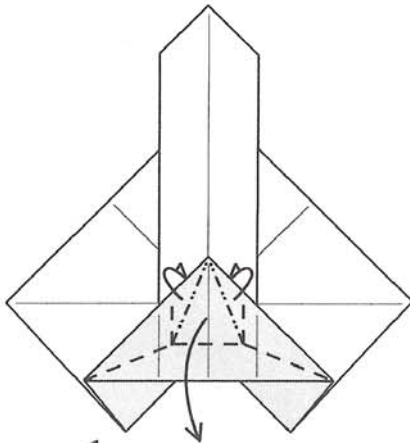

**1**  
Plis pivots.

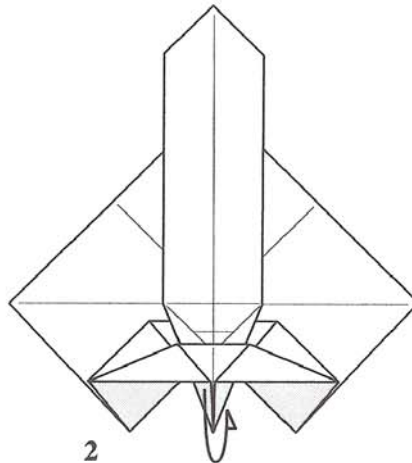

**2**  
Basculer la queue derrière.

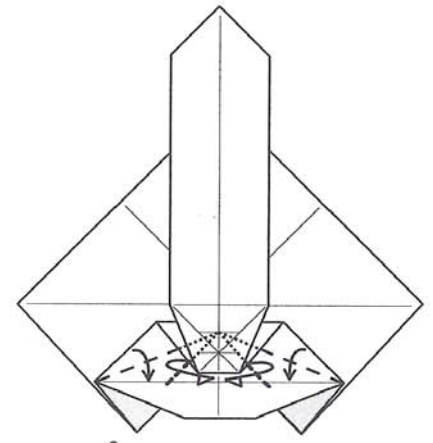

**3**  
Replis.

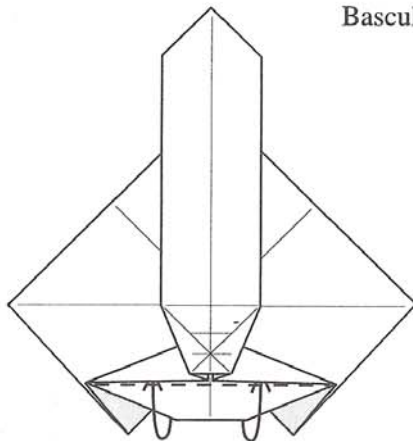

**4**  
Insérer dans la poche.

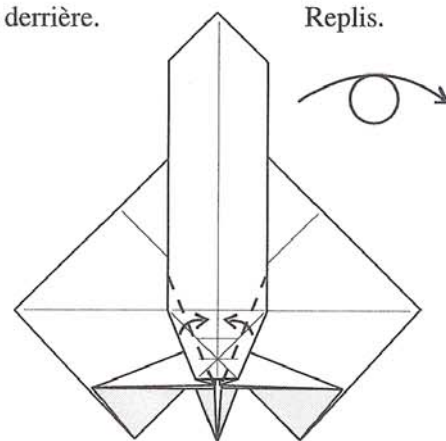

**5**  
Plis vallées.  
Retourner le modèle.

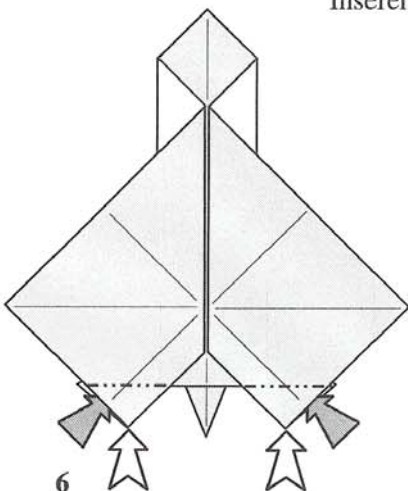

**6**  
Plis inversés.

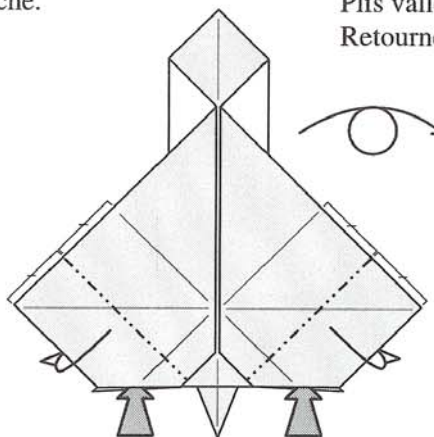

**7**  
Plier derrière.  
Retourner le modèle.

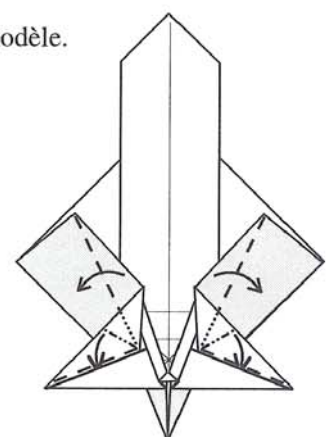

**8**  
Insérer dans les poches.

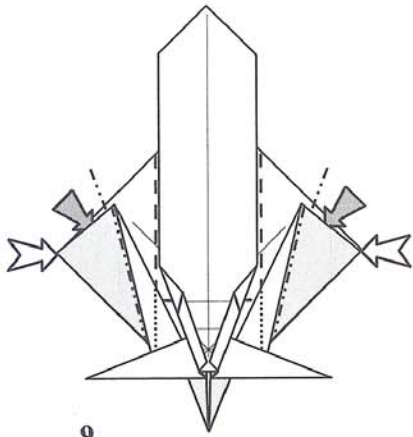

**9**  
Plis inversés.

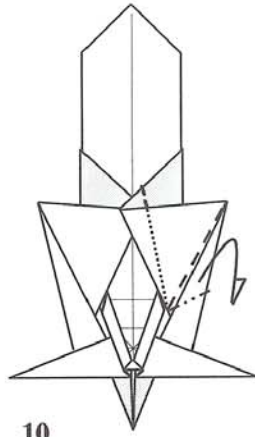

**10**  
Dégager une patte.

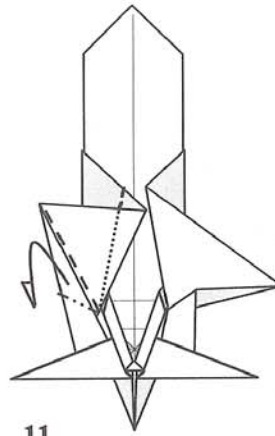

**11**  
Répéter l'étape 10 à gauche.

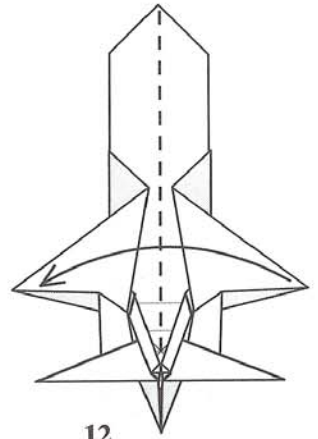

**12**  
Fermer le modèle.

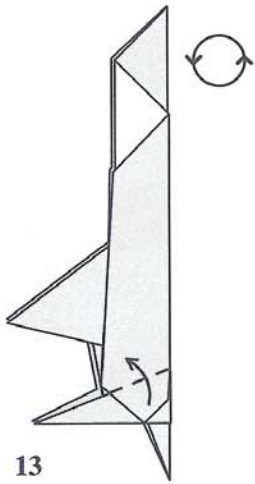

**13**  
Pli vallée.  
Rotation du modèle.  
Répéter derrière.

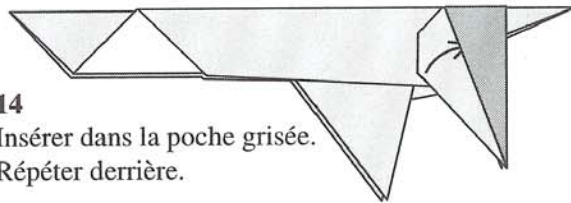

**14**  
Insérer dans la poche grisée.  
Répéter derrière.

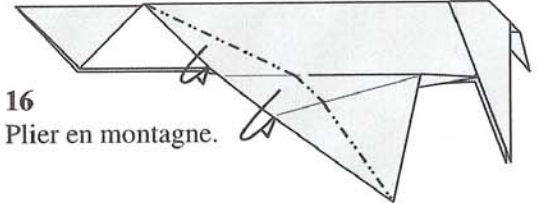

**16**  
Plier en montagne.

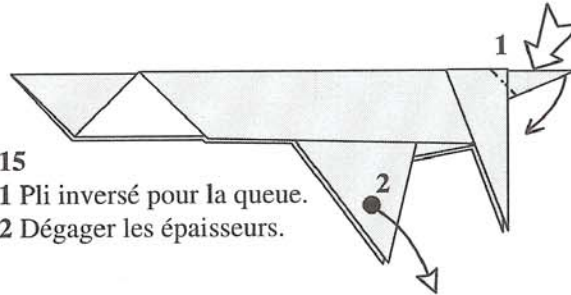

**15**  
1 Pli inversé pour la queue.  
2 Dégager les épaisseurs.

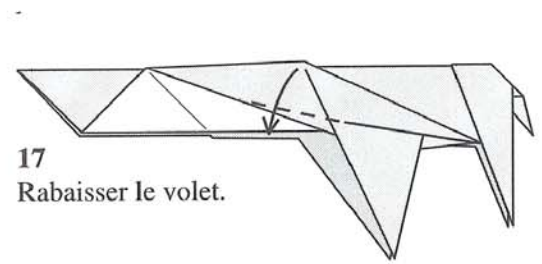

**17**  
Rabaisser le volet.

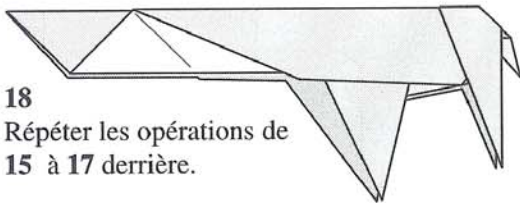

**18**  
Répéter les opérations de  
15 à 17 derrière.

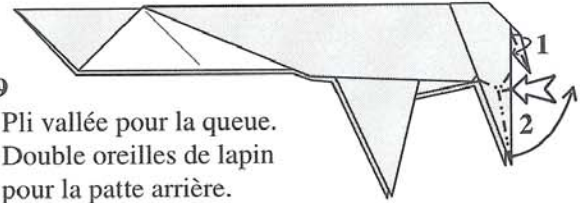

**19**  
1 Pli vallée pour la queue.  
2 Double oreilles de lapin  
pour la patte arrière.  
Répéter derrière.

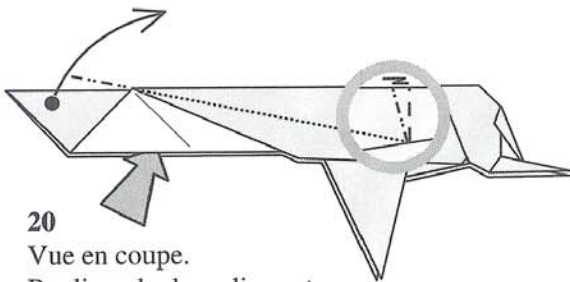

**20**  
Vue en coupe.  
Repli sur le dos, pli montagne  
pour relever la pointe.

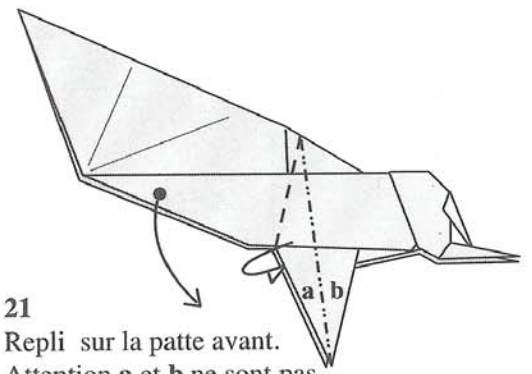

**21**  
Repli sur la patte avant.  
Attention **a** et **b** ne sont pas  
des angles égaux.  
Répéter derrière.

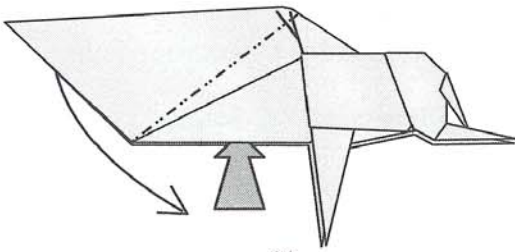

22  
Pli inversé.

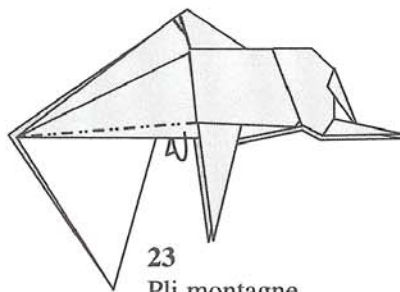

23  
Pli montagne.  
Répéter derrière.

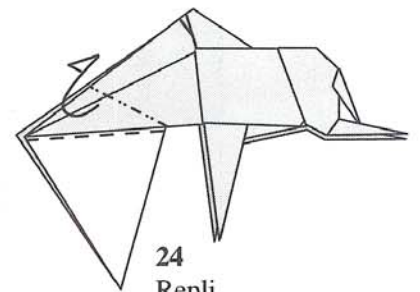

24  
Repli.  
Répéter derrière.

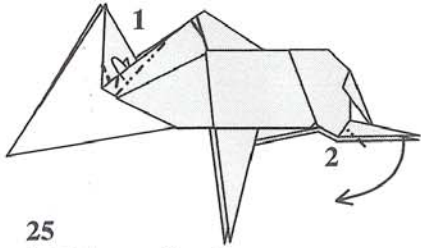

25  
1 Pli inversé intérieur.  
2 Pli inversé intérieur  
pour la patte arrière.  
Répéter derrière.

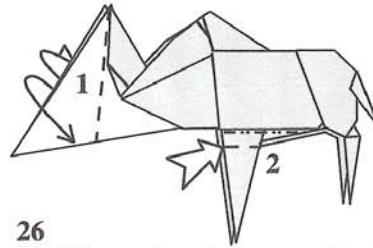

26  
1 Pli inversé extérieur pour la tête.  
2 Repli pour la patte avant.  
Répéter derrière.

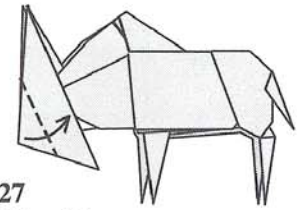

27  
Pli vallée.

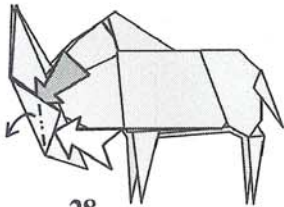

28  
Pli aplati.

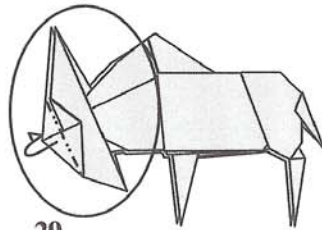

29  
Plier derrière.  
Sélection de la zone de travail.

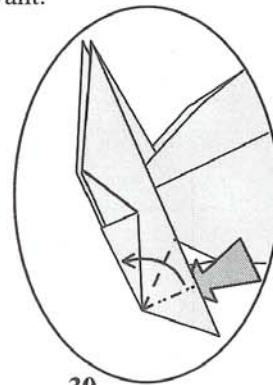

30  
Pli aplati.

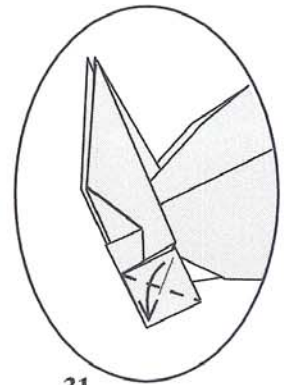

31  
Pli vallée.

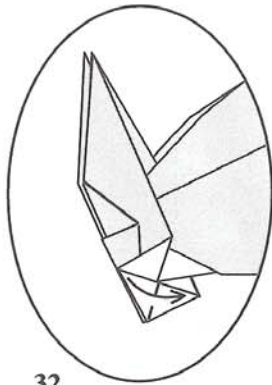

32  
Pli vallée.

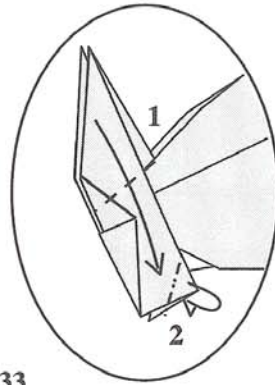

33  
1 Pli vallée pour la corne.  
2 Pli montagne pour la mâchoire.  
Répéter derrière.

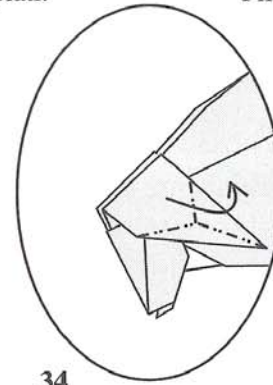

34  
Pincer et courber la corne.  
Répéter derrière.

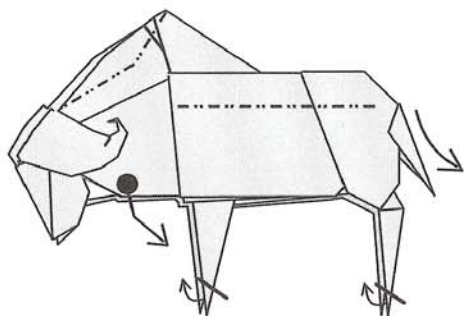

35  
Modelage final.

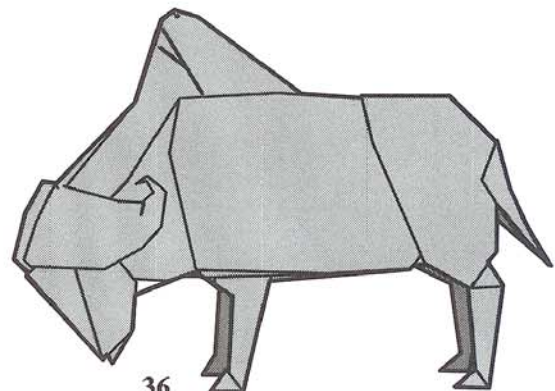

36  
BUFFLE TERMINE.

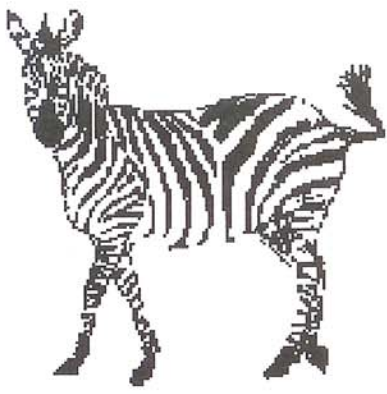

# ZEBRE

Niveau de difficulté : Intermédiaire

Carré couleur : Recto

Format : 30 cm

Modèle terminé : 11 cm

Papier : 80 g

Pour le sens des rayures du Zèbre reportez vous au dessin A.

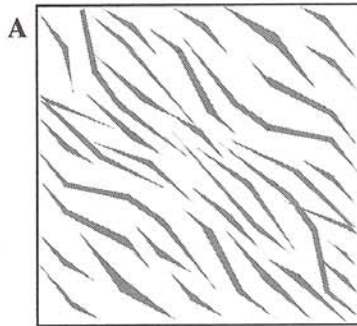

Le dessin B vous donne le sens des rayures à l'étape 7 de la gazelle.

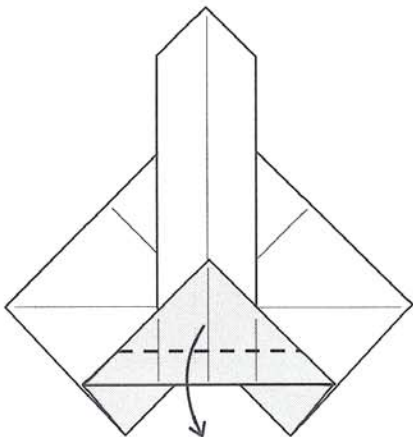
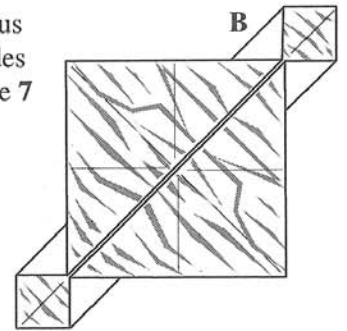

**1**  
Pli vallée.

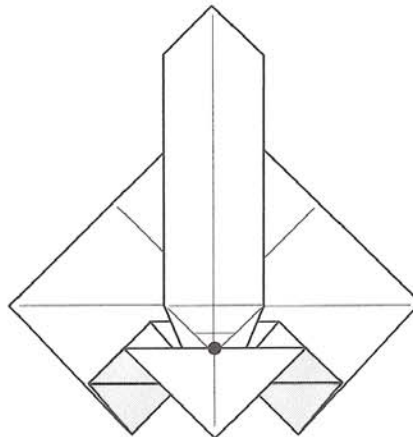

**2**  
Le pli vallée de l'étape 1 doit se situer au-dessus de l'intersection des marques des plis indiquées par le point.

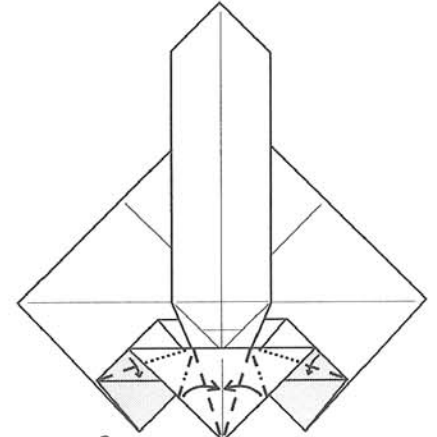

**3**  
Plis pivots.

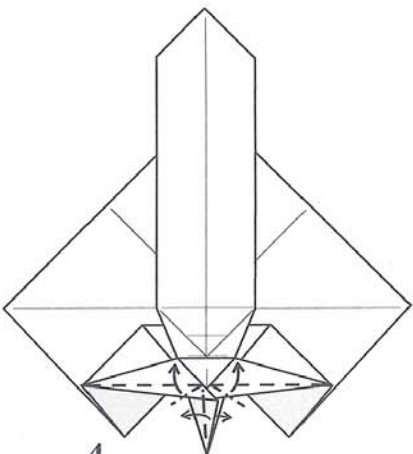

**4**  
Plis pivots.

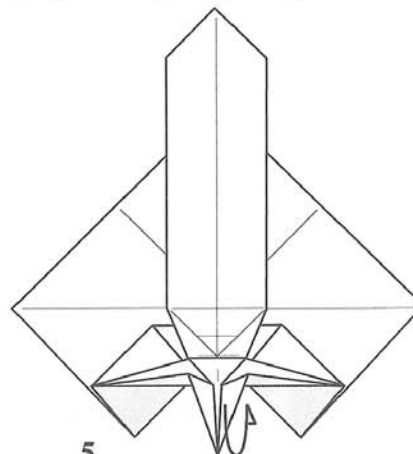

**5**  
Basculer la queue derrière.

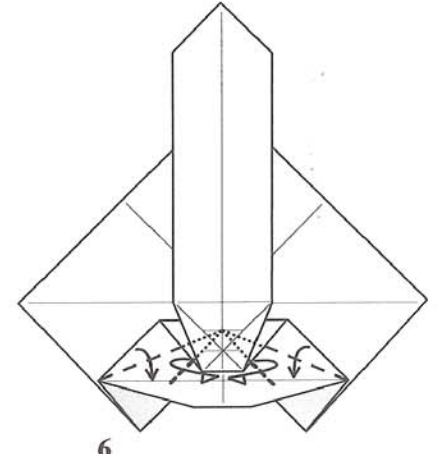

**6**  
Replis.

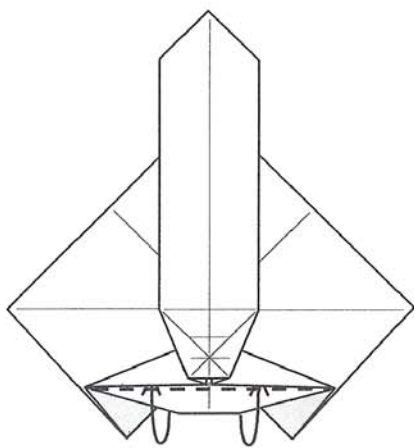

**7**  
Insérer dans la poche.

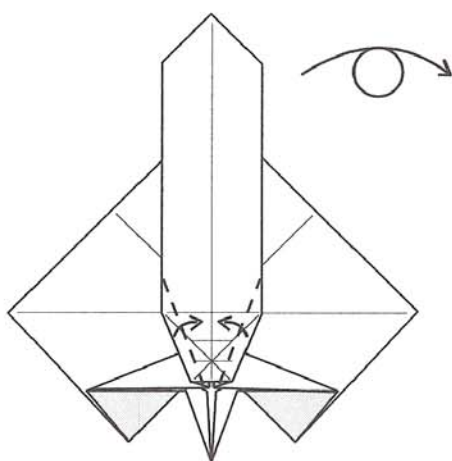

**8**  
Plis vallées.  
Retourner le modèle.

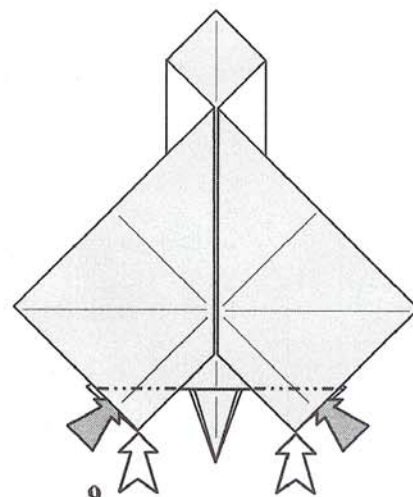

**9**  
Plis inversés.

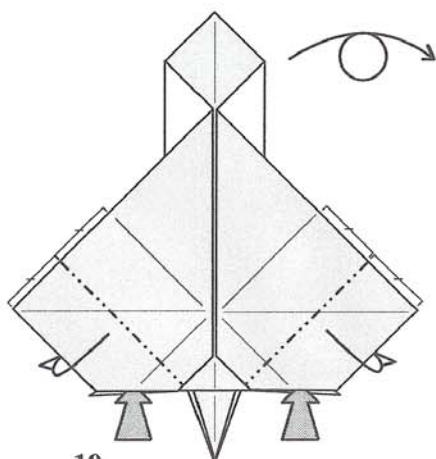

**10**  
Plis montagnes.  
Retourner le modèle.

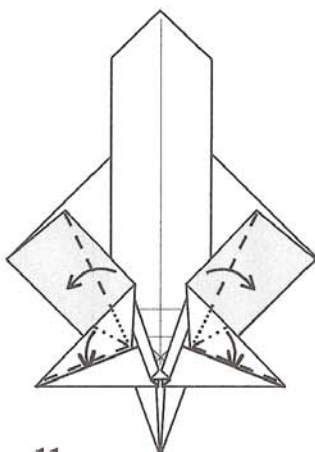

**11**  
Insérer dans les poches.

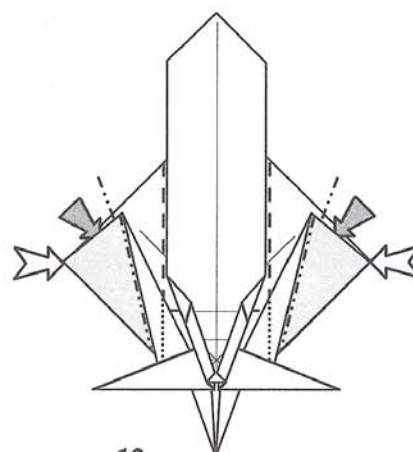

**12**  
Plis inversés.

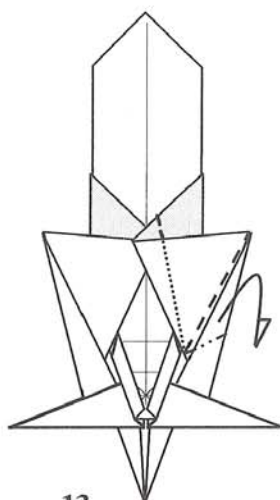

**13**  
Dégager une  
patte.

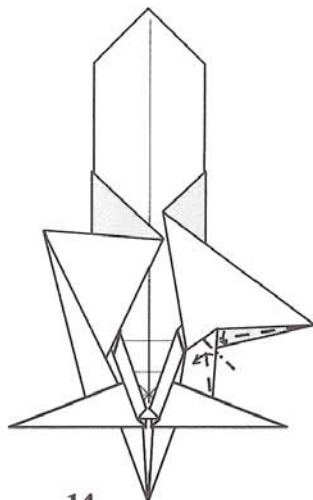

**14**  
Pli pivot.

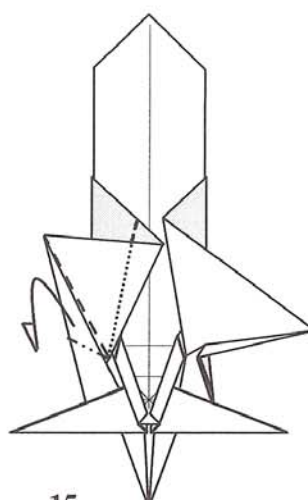

**15**  
Répéter les étapes  
13 et 14 à gauche.

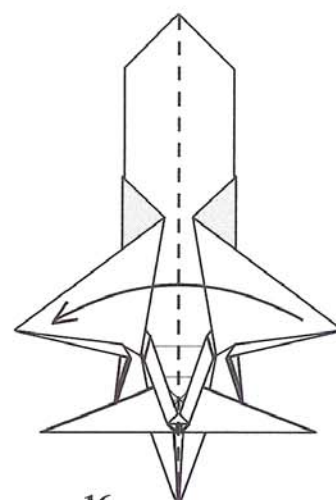

**16**  
Fermer le modèle.

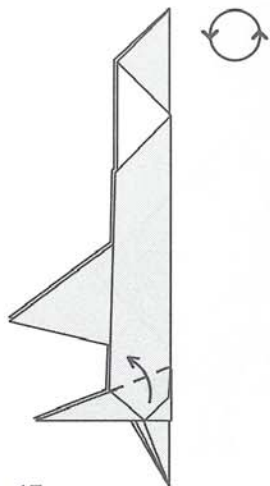

**17**  
Pli vallée.  
Répéter derrière.  
Rotation du modèle

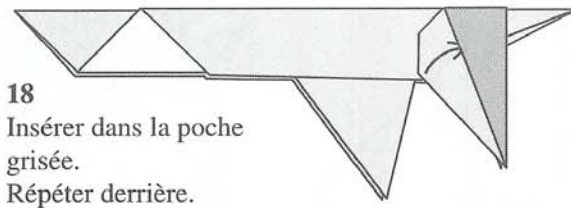

**18**  
Insérer dans la poche  
grisée.  
Répéter derrière.

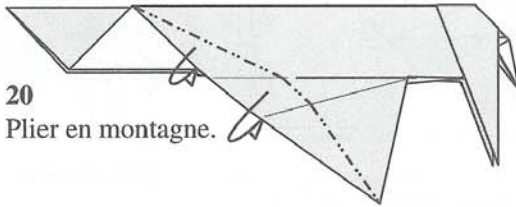

**20**  
Plier en montagne.

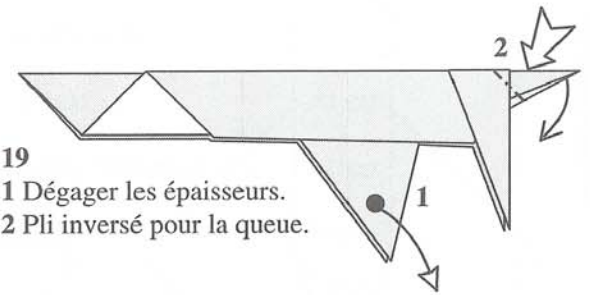

**19**  
1 Dégager les épaisseurs.  
2 Pli inversé pour la queue.

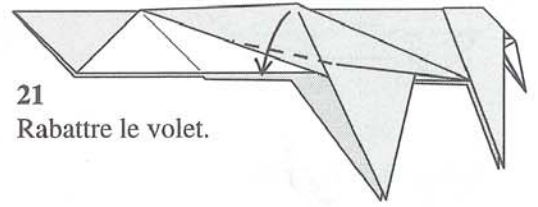

**21**  
Rabattre le volet.

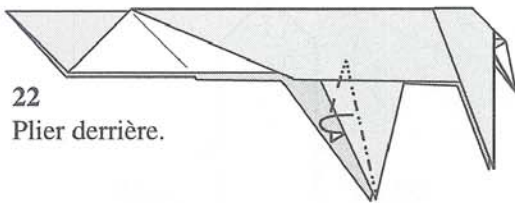

**22**  
Plier derrière.

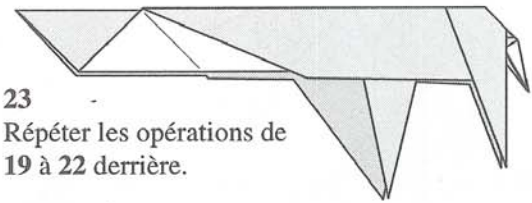

**23**  
Répéter les opérations de  
19 à 22 derrière.

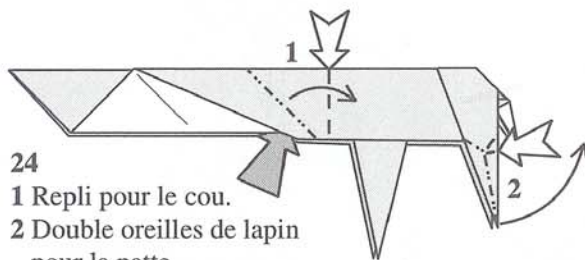

**24**  
1 Repli pour le cou.  
2 Double oreilles de lapin  
pour la patte.  
Répéter derrière.

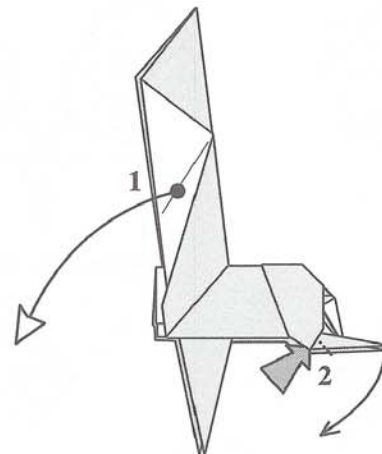

**25**  
1 Positionner la tête  
comme en 24.  
2 Pli inversé pour  
former la patte.  
Répéter derrière.

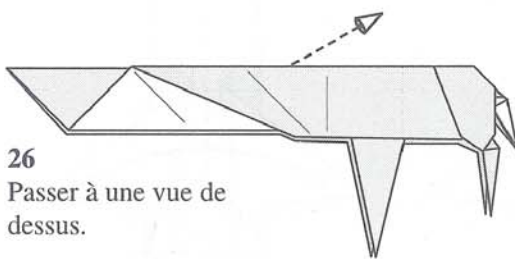

**26**  
Passer à une vue de  
dessus.

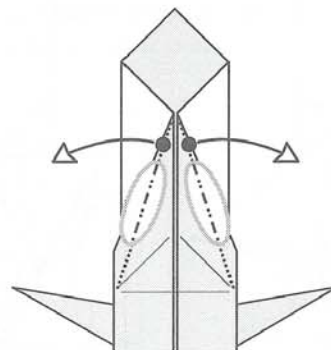

**27**  
Vue en coupe.  
Ecarter les deux volets et  
marquer les plis montagnes.

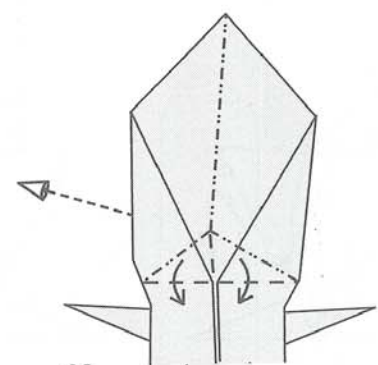

**28**  
Reformer les plis en utilisant les  
marques des plis exécutées en 24.  
Repasser en vue de côté.



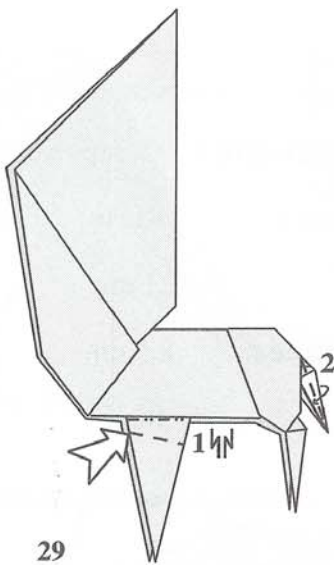

**29**  
1 Repli pour la patte.  
2 Pli vallée pour la queue.  
Répéter derrière.

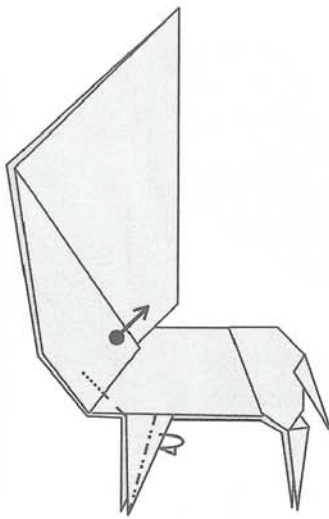

**30**  
1 Pincer et remonter l'encolure.  
2 Pli montagne pour amincir la patte.  
Répéter derrière.

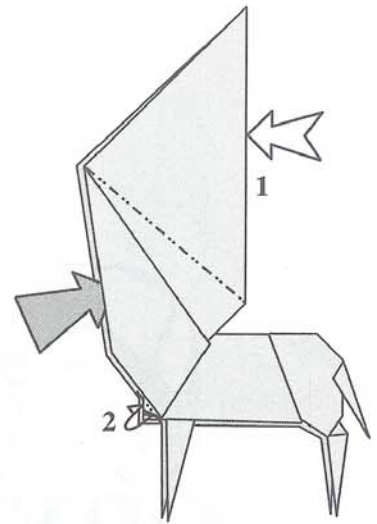

**31**  
1 Pli inversé pour former la tête.  
2 Petit pli montagne pour cacher les épaisseurs.  
Répéter derrière.

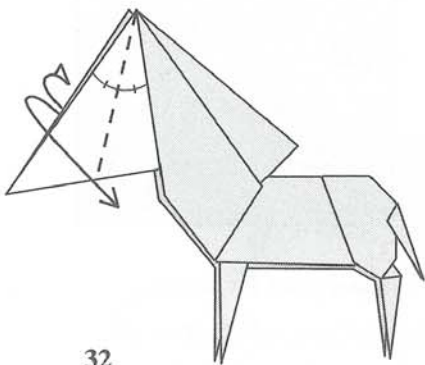

**32**  
Pli inversé extérieur pour la tête.

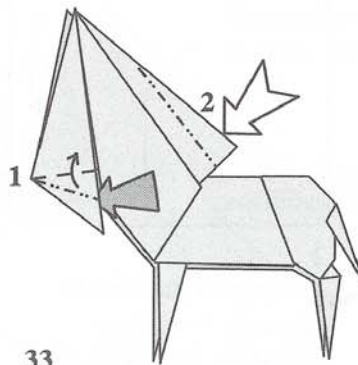

**33**  
1 Pli aplati pour la mâchoire.  
2 Enfoncement ouvert pour la crinière.

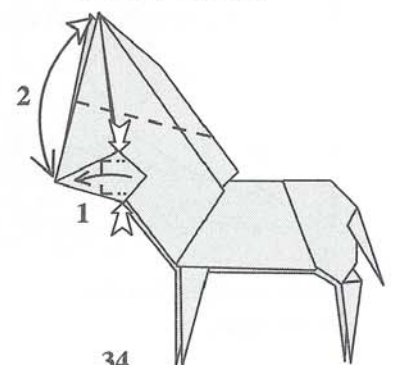

**34**  
1 Pli pétale pour la mâchoire.  
2 Plier, déplier pour la tête.  
Répéter derrière.

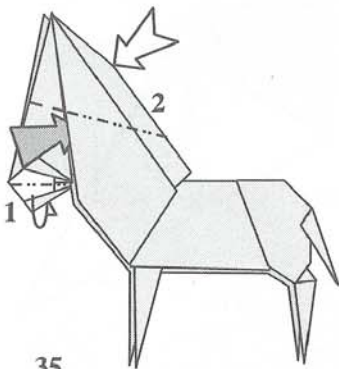

**35**  
1 Pli montagne pour la mâchoire.  
2 Pli inversé pour la tête.  
Répéter derrière.

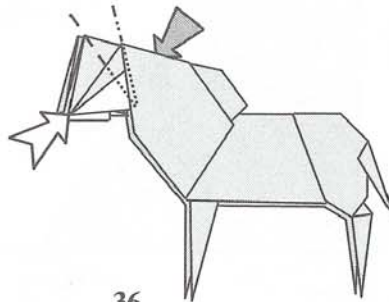

**36**  
Pli inversé pour former l'oreille.  
Répéter derrière.

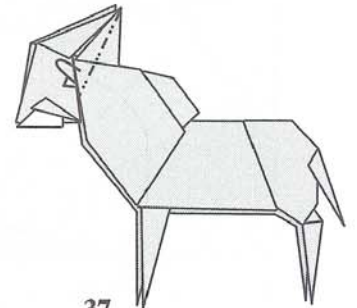

**37**  
Pli montagne.  
Répéter derrière.

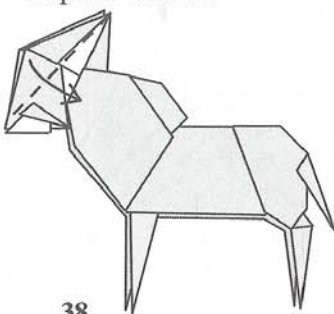

**38**  
Pli vallée.  
Répéter derrière.

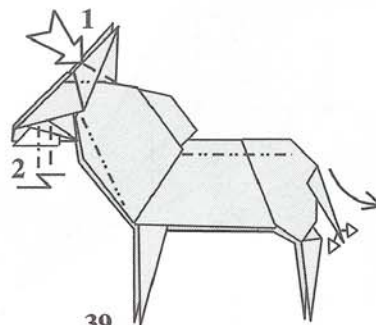

**39**  
1 Enfoncement pour l'oreille.  
Répéter derrière.  
2 Repli pour la mâchoire.  
Modelage final.

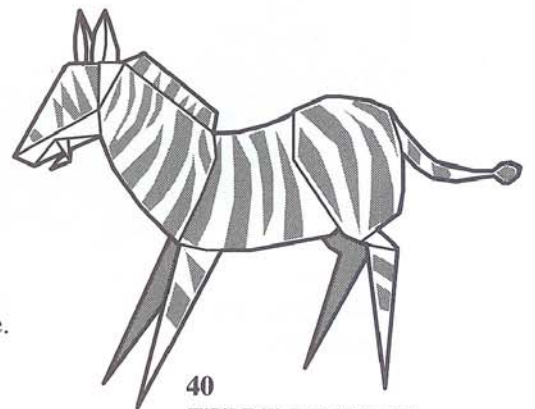

**40**  
ZEBRE TERMINE.

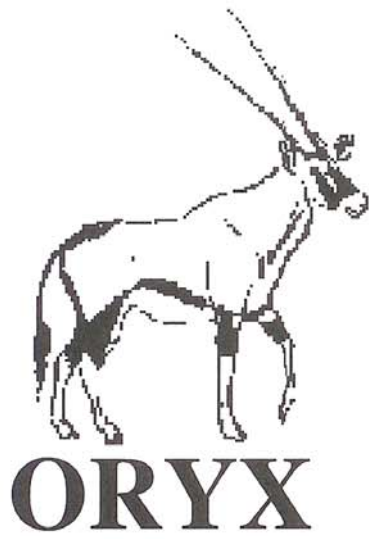

**Niveau de difficulté :** Complexe

**Carré couleur :** Recto

**Format :** 21 cm

**Modèle terminé :** 8,5 cm

**Papier :** 80 g

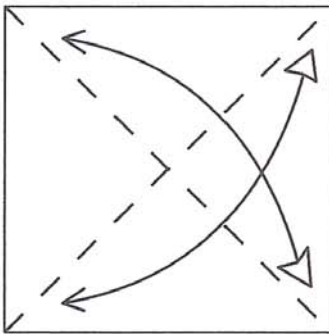

**1**  
Plier et déplier les deux diagonales.

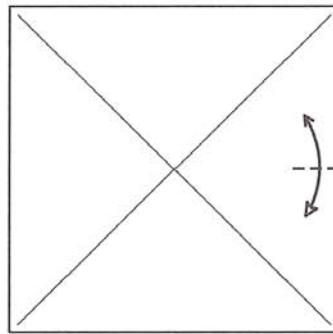

**2**  
Pincer pour marquer le départ de la médiane. Retourner le modèle.

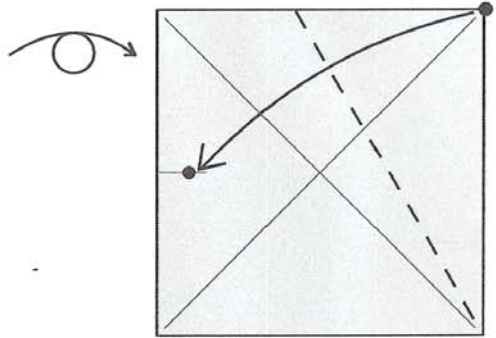

**3**  
Superposer les points.

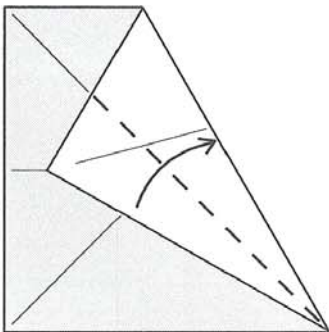

**3**  
Pli vallée.

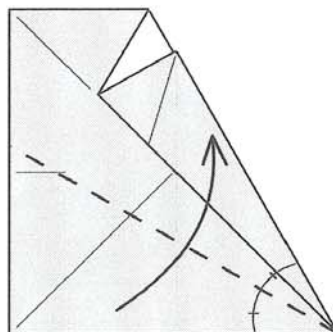

**5**  
Plier la bissectrice.

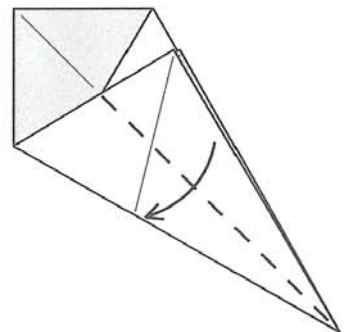

**6**  
Pli vallée.

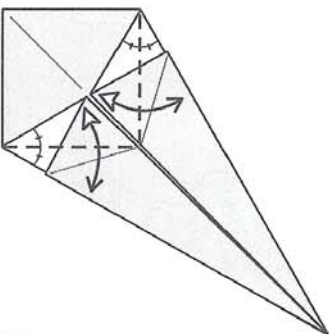

**7**  
Plier, déplier les bissectrices.

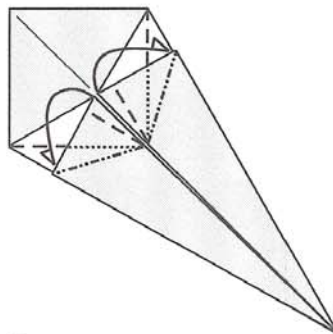

**8**  
Plis inversés intérieurs.

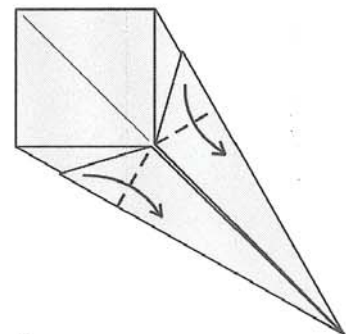

**9**  
Plis vallées.

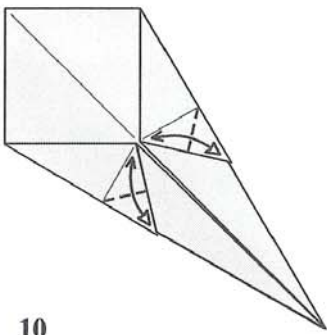

**10**  
Plier, déplier.

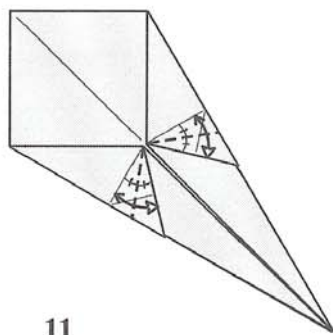

**11**  
Plier, déplier les  
bissectrices.

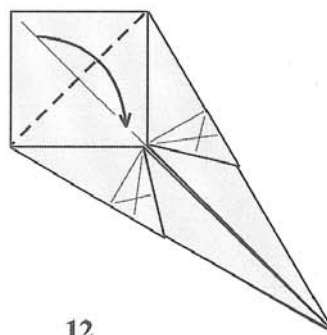

**12**  
Pli vallée.

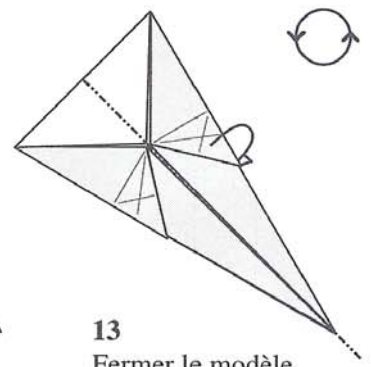

**13**  
Fermer le modèle.  
Rotation du modèle.

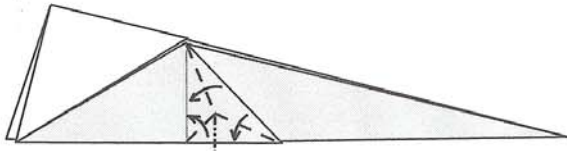

**14**  
Pli oreille de lapin.  
Répéter derrière.

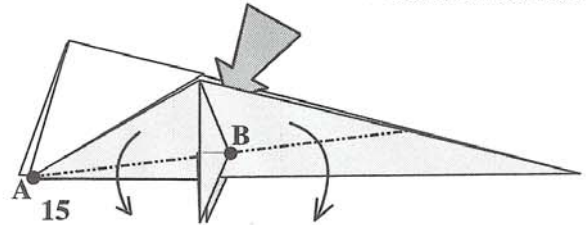

**15**  
Plier en montagne.  
Utiliser les points A et B pour construire ce pli.  
Répéter derrière.

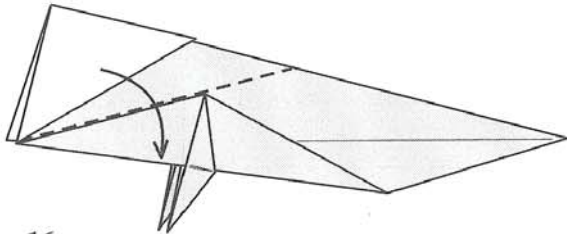

**16**  
Pli vallée le long de l'épaisseur.

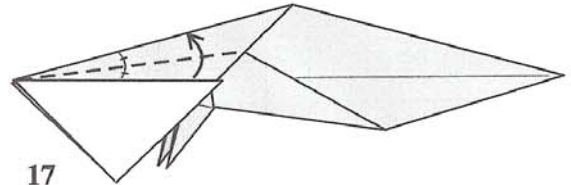

**17**  
Plier la bissectrice.

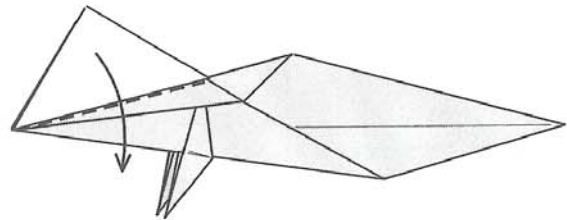

**18**  
Pli vallée le long de l'épaisseur.

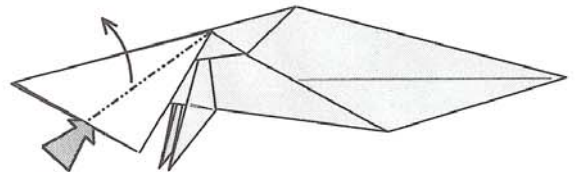

**19**  
Pli aplati.

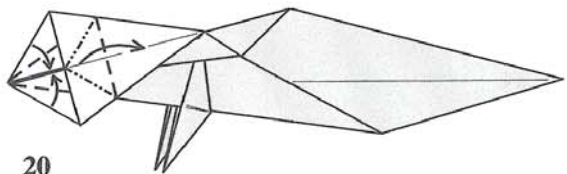

**20**  
Pli pétale.

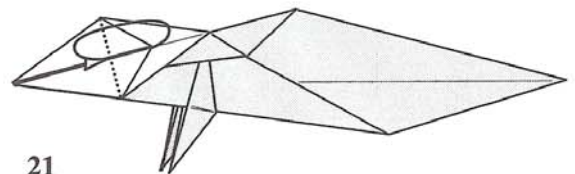

**21**  
Glisser le triangle derrière.

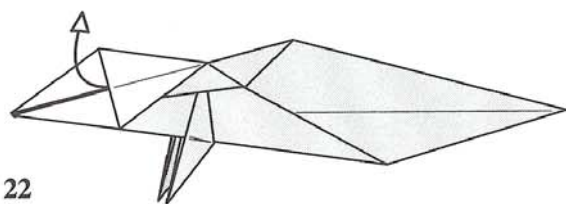

**22**  
Déplier le modèle de 6 étapes  
présentez-le comme en 16.

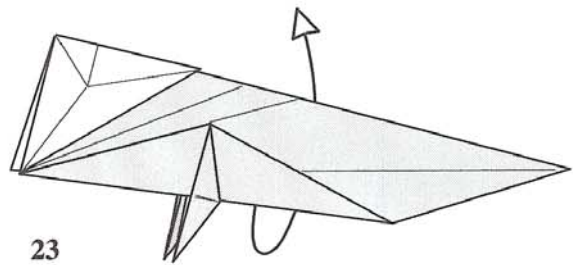

**23**  
Ouvrir le modèle.

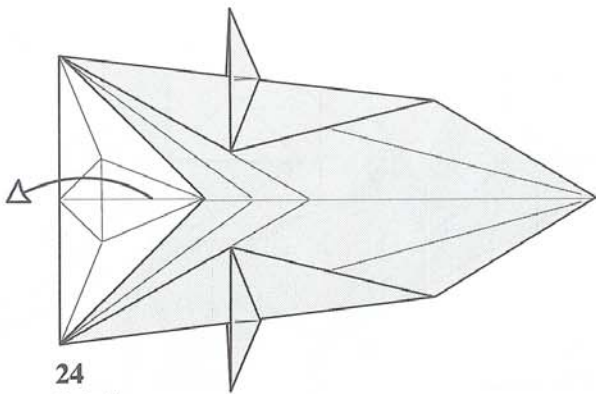

**24**  
Déplier.

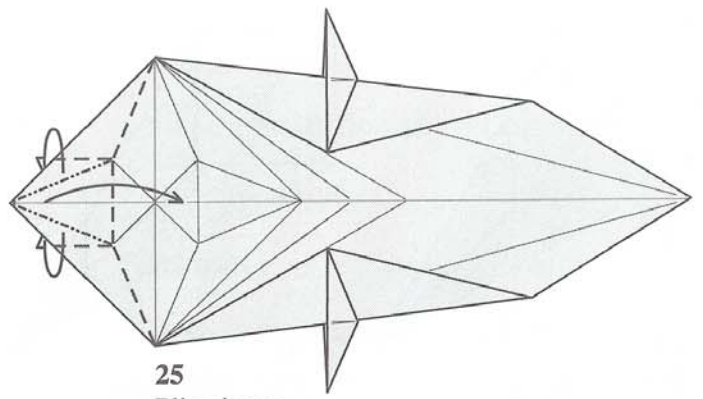

**25**  
Plis pivots.

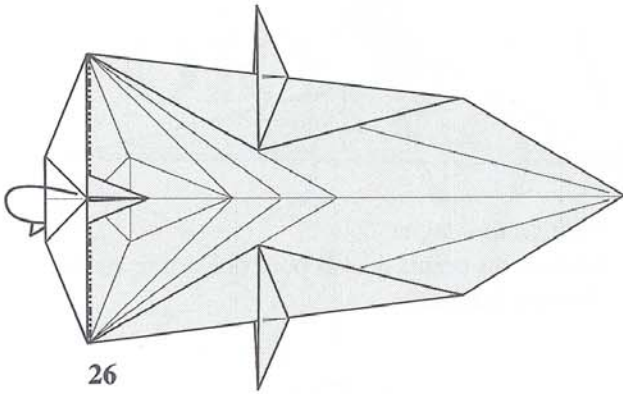

**26**  
Plier derrière.

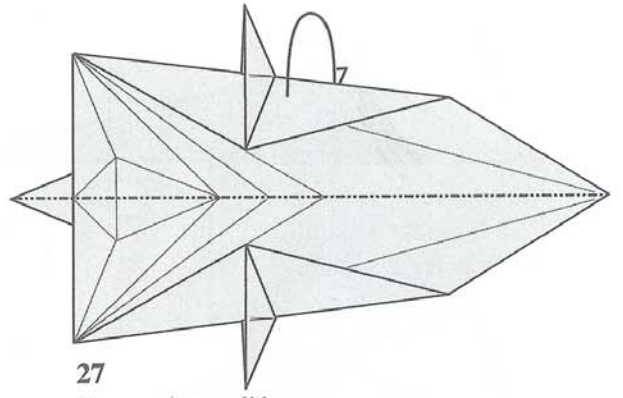

**27**  
Fermer le modèle.

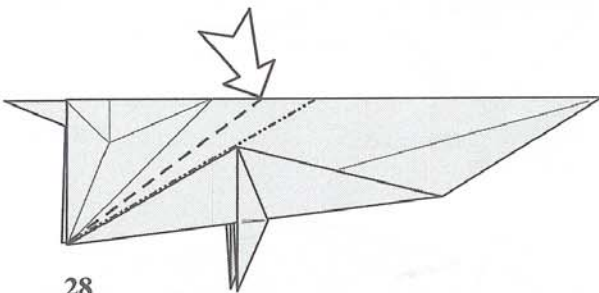

**28**  
Enfoncement avec repli.

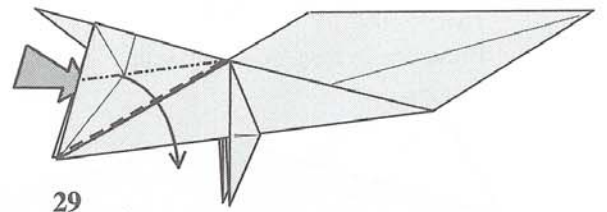

**29**  
Pli aplati.

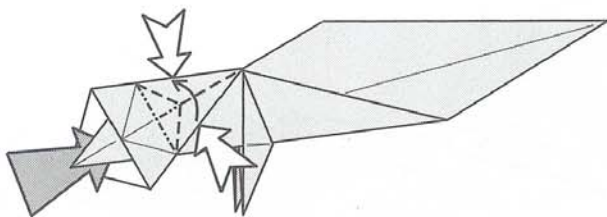

**30**  
Plier le triangle en utilisant  
les bissectrices.

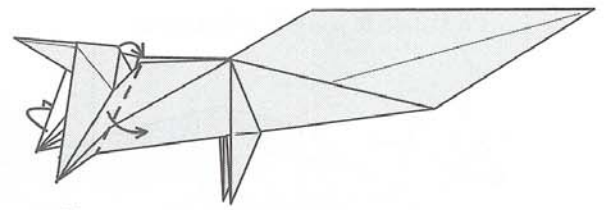

**31**  
Vue 3D du pli 30.  
Rapprocher les pattes arrière le long du corps.

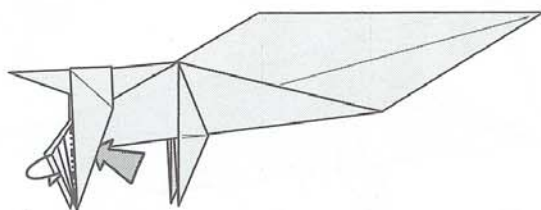

**32**  
Pli inversé intérieur.  
Répéter derrière.

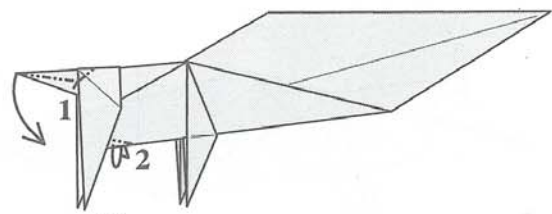

**33**  
1 Double oreilles de lapin pour la queue.  
2 Mincir le ventre.  
Répéter derrière.

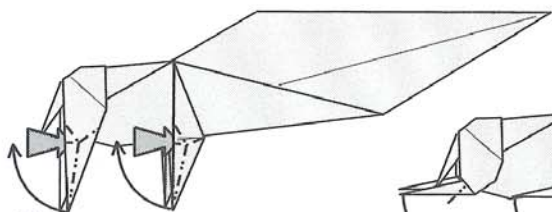

**34**  
Double oreilles de lapin pour la  
patte avant et arrière.  
Répéter derrière.

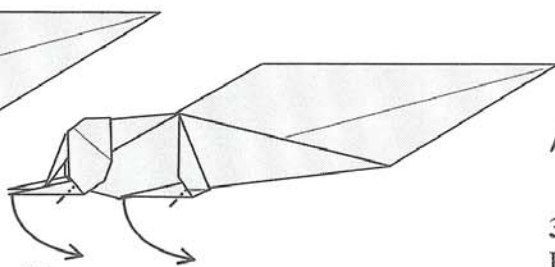

**35**  
Plis inversés intérieurs pour la  
patte avant et arrière.  
Répéter derrière.

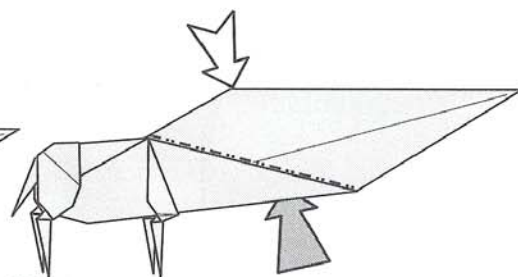

**36**  
Pli inversé intérieur pour la tête.

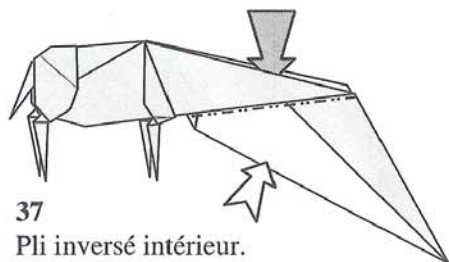

**37**  
Pli inversé intérieur.

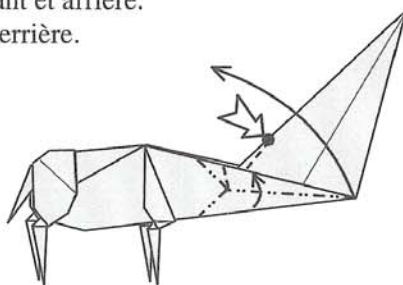

**38**  
Pli oreille de lapin sur la corne  
tout en pratiquant un pli inversé  
intérieur sur la grande pointe.

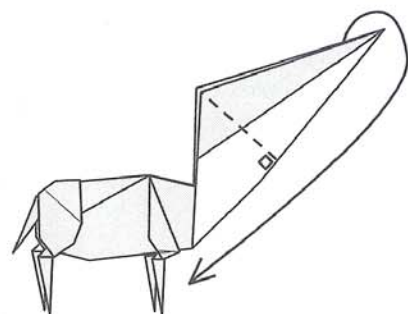

**39**  
Pli perpendiculaire inversé  
intérieur.

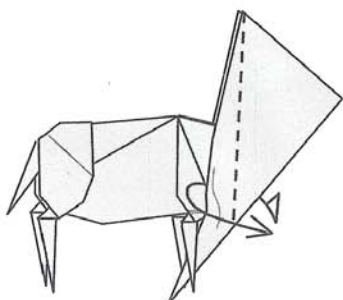

**40**  
Pli inversé extérieur sur la zone  
excédentaire de la pointe.  
Répéter derrière.

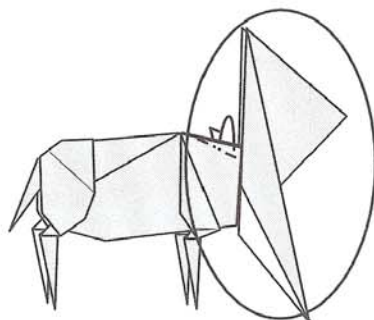

**41**  
Pli montagne pour diminuer l'encolure.  
Répéter derrière.  
Sélection de la zone de travail.

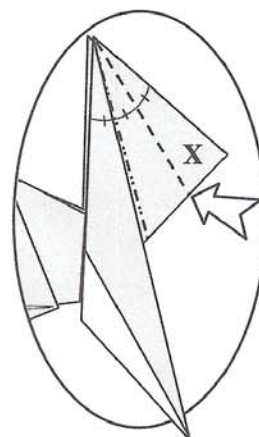

**42**  
Subdiviser l'angle de la corne par trois.  
Pli inversé intérieur avec repli.

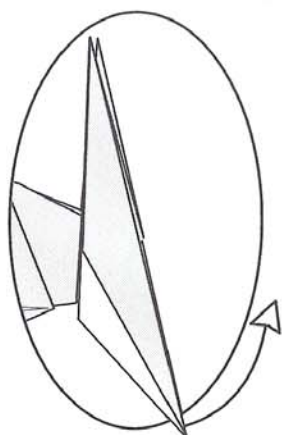

**43**  
Dégager la pointe.

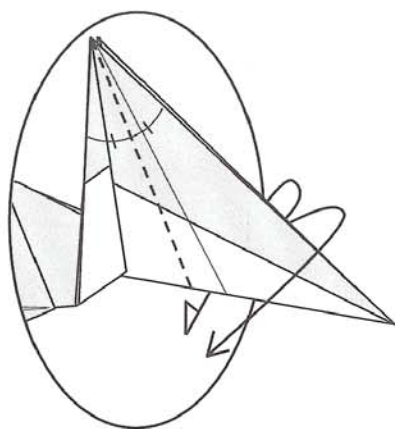

**44**  
Pli inversé extérieur  
sur la bissectrice.

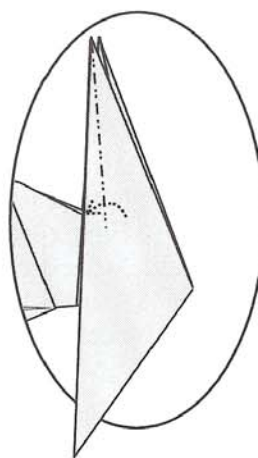

**45**  
Pli inversé intérieur sur  
le rabat X plié en 42.

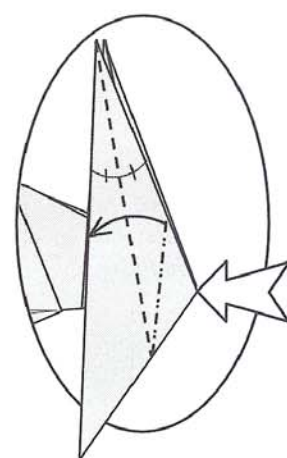

**46**  
Repli avec  
enfoncement étiré.  
Répéter derrière.

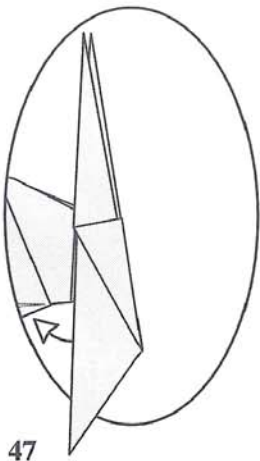

**47**  
Sortir l'épaisseur.  
Répéter derrière.

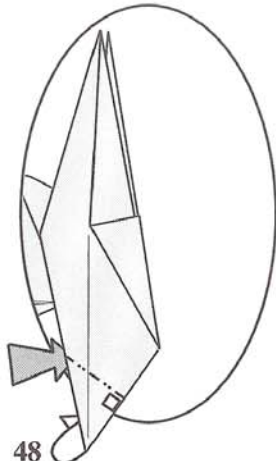

**48**  
Pli inversé intérieur.

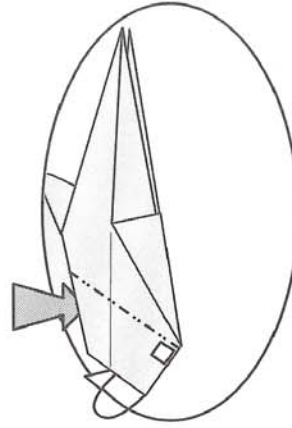

**49**  
Pli inversé intérieur.

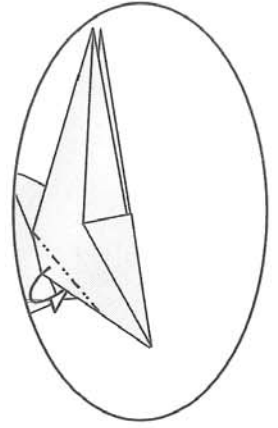

**50**  
Pli montagne.  
Répéter derrière.

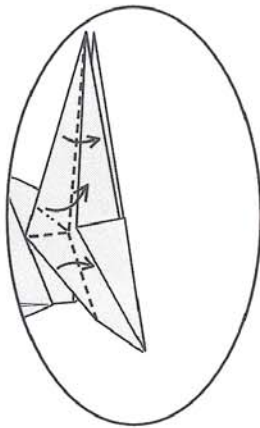

**51**  
Pli oreille de lapin.  
Répéter derrière.

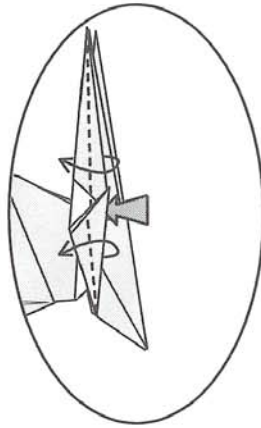

**52**  
Pli inversé extérieur.  
Répéter derrière.

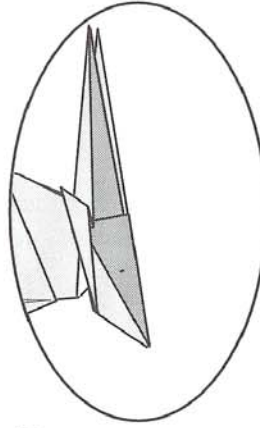

**53**  
Placer la zone sombre dessus.  
Répéter derrière.

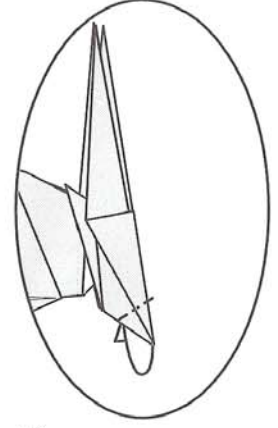

**54**  
Raccourcir le museau.

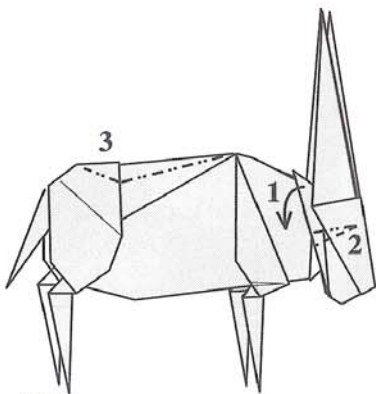

**55**  
1 Dégager l'oreille.  
2 Repli pour former l'oeil.  
Répéter derrière.  
3 Former le dos.

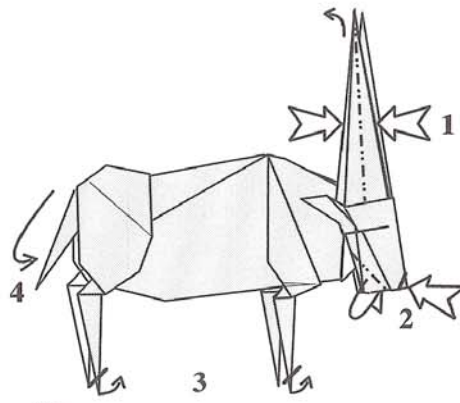

**56**  
1 Affiner les cornes.  
2 Former le museau.  
3 Former les pattes.  
Répéter derrière.  
4 Courber la queue.  
Modelage final.

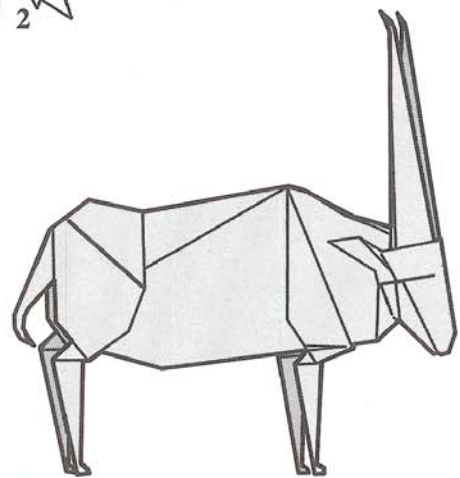

**57**  
ORYX TERMINE

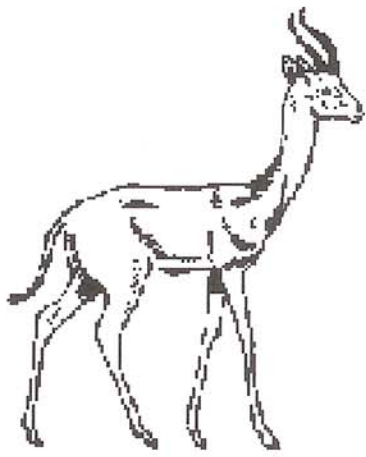

# GENERUK

Niveau de difficulté : Intermédiaire

Carré couleur : Recto

Format : 21 cm

Modèle terminé : 10 cm

Papier : 80 g

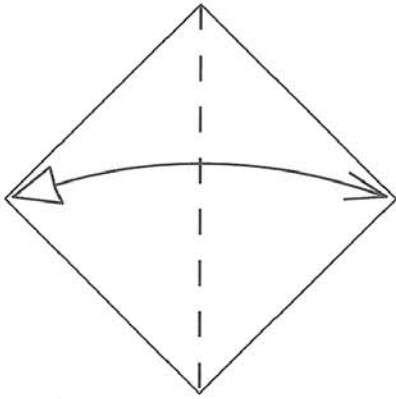

**1**  
Plier, déplier la diagonale en vallée.

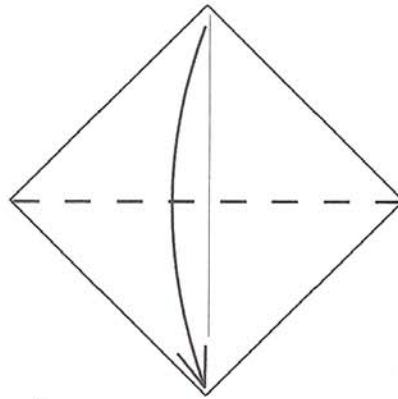

**2**  
Pli vallée sur l'autre diagonale.

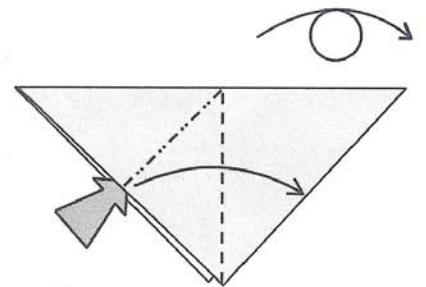

**3**  
Pli aplati.

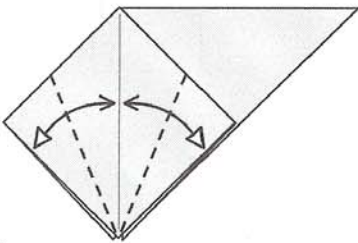

**4**  
Plier, déplier.

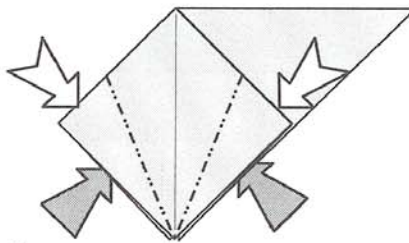

**5**  
Plis inversés intérieurs.

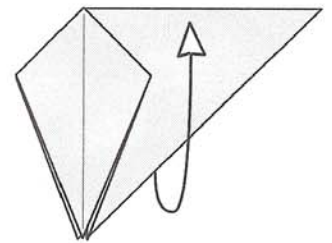

**6**  
Déplier totalement le modèle.

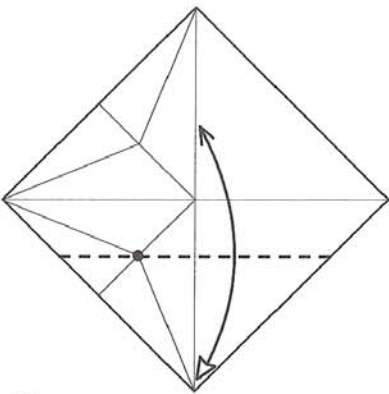

**7**  
Plier, déplier à l'intersection indiquée par le point.

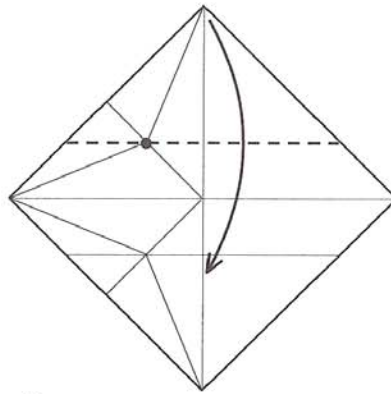

**8**  
Plier en vallée sur l'autre intersection indiquée par le point.

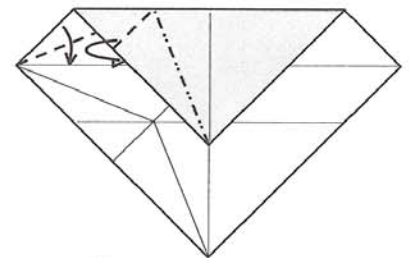

**9**  
Pli pivot.

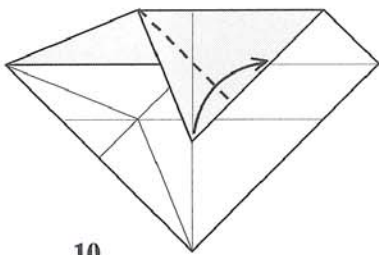

**10**  
Pli vallée.

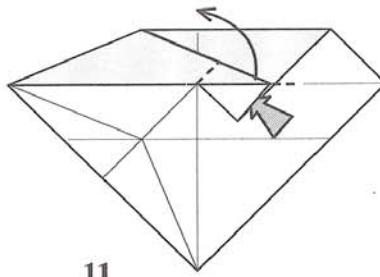

**11**  
Pli aplati.

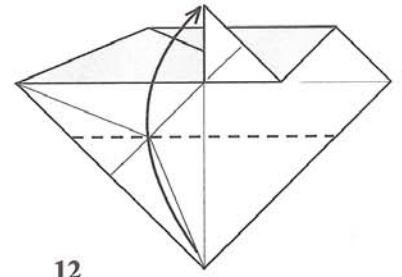

**12**  
Répéter les opérations  
de 8 à 11 sur l'autre coin.

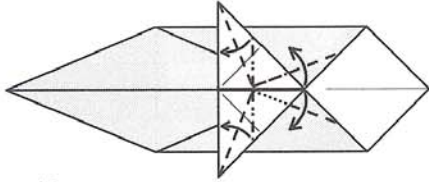

**13**  
Plis pivots.

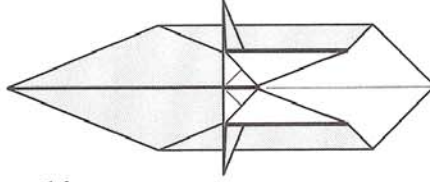

**14**  
**Attention** les lignes indiquées en  
gras sont parallèles.

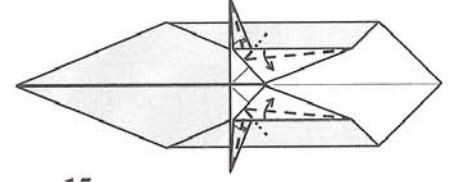

**15**  
Plis pivots.

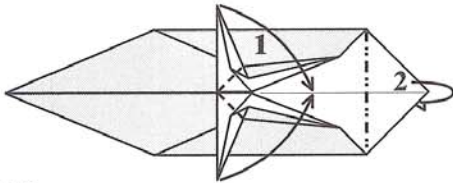

**16**  
1 Plier les deux pointes sur  
l'axe de symétrie.  
2 Plier derrière.

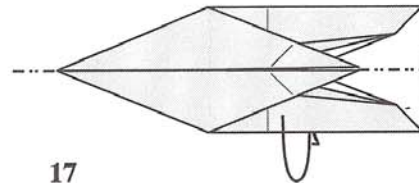

**17**  
Fermer le modèle.

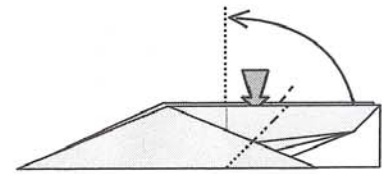

**18**  
Pli inversé intérieur.

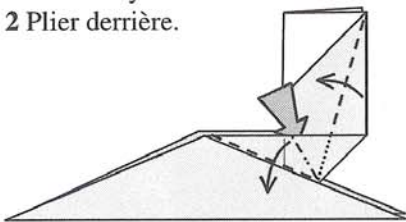

**19**  
Pli pivot.  
Répéter derrière.

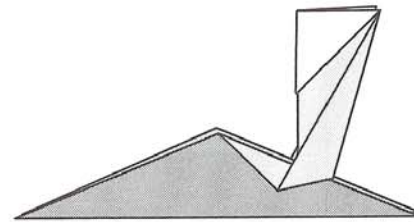

**20**  
Passer la zone sombre par dessus.  
Répéter derrière.

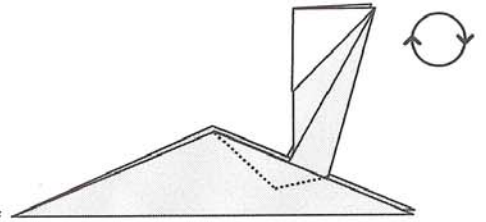

**21**  
Rotation du modèle.

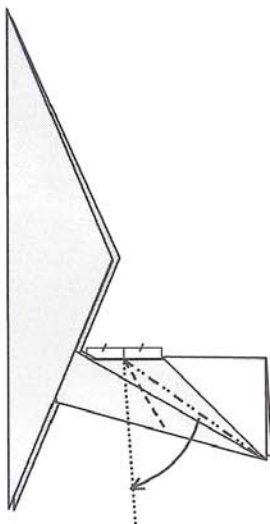

**22**  
Repli pour la patte arrière.  
Répéter derrière.

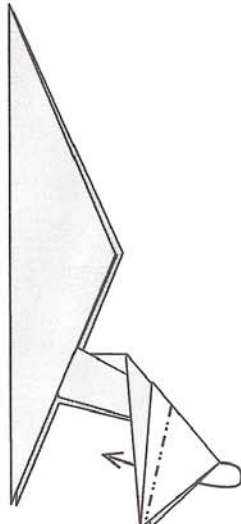

**23**  
Pli inversé intérieur.

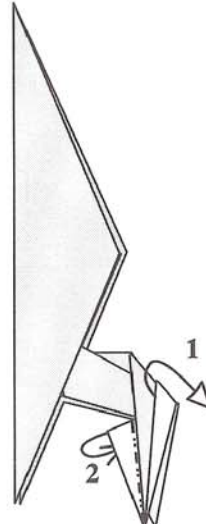

**24**  
1 Dégager la queue.  
2 Pli inversé intérieur.

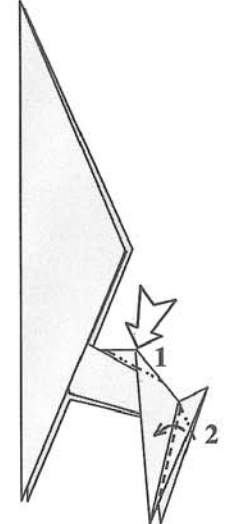

**25**  
1 Enfoncement fermé  
pour le dos.  
2 Repli pour la queue.



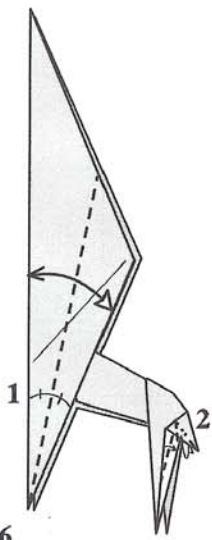

26  
1 Plier, déplier.  
2 Diminuer la queue.  
Répéter derrière.

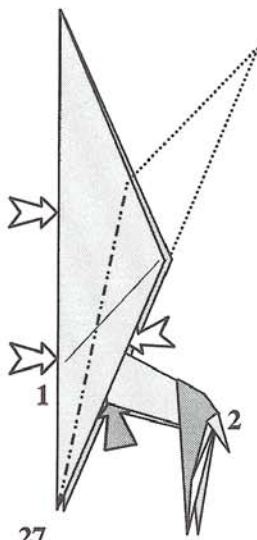

27  
1 Pli inversé intérieur.  
2 Placer la zone sombre dessus.  
Répéter derrière.

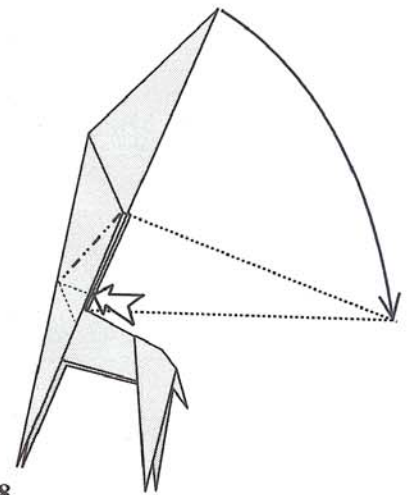

28  
Pli inversé intérieur utilisant une marque de pli pour le pli montagne.  
Répéter derrière.

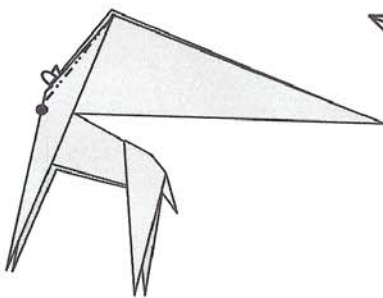

29  
Mincir le cou.  
**Attention** le pli montagne s'arrête avant le blocage indiqué par le point.  
Répéter derrière.

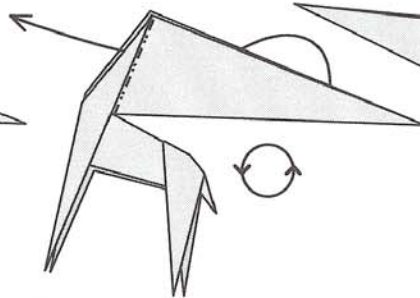

30  
Pli inversé intérieur.  
Petite rotation.

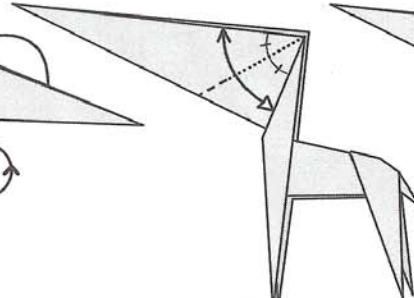

31  
Plier, déplier.

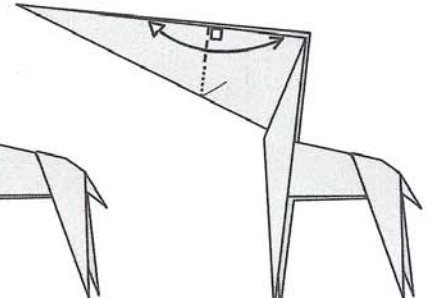

32  
Plier, déplier.

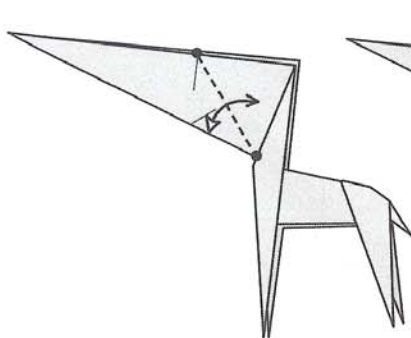

33  
Plier, déplier.

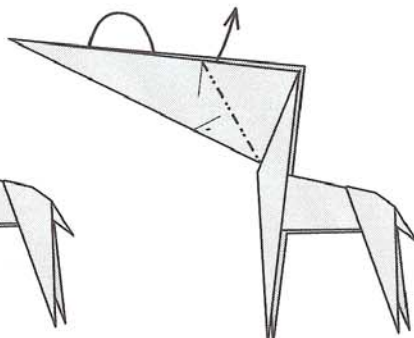

34  
Pli inversé intérieur.

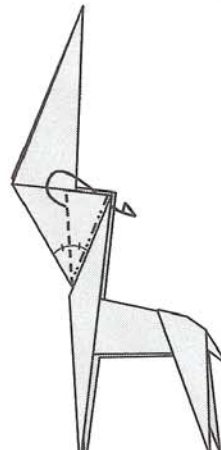

35  
Repli.  
Répéter derrière.

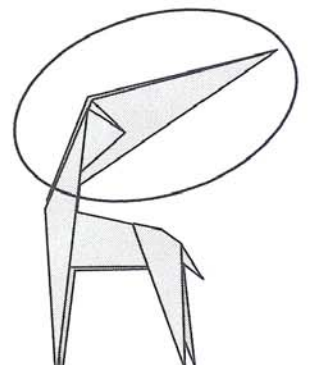

36  
Sélection de la zone de travail.

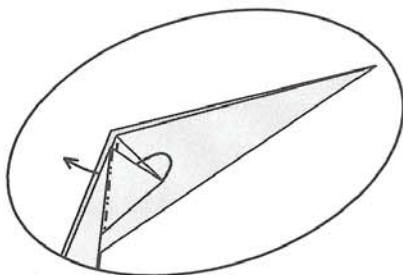

37  
Pli inversé intérieur.  
Répéter derrière.

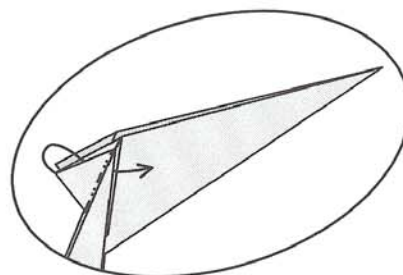

38  
Pli inversé intérieur.  
Répéter derrière.

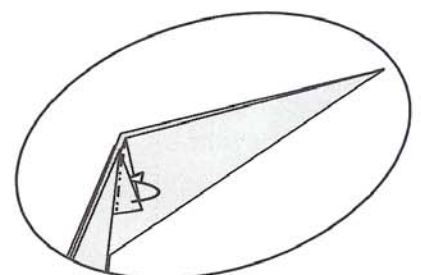

39  
Pli inversé intérieur.  
Répéter derrière.

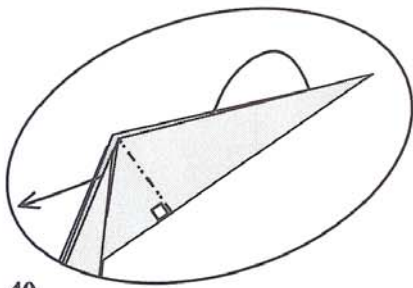

40  
Pli inversé intérieur.

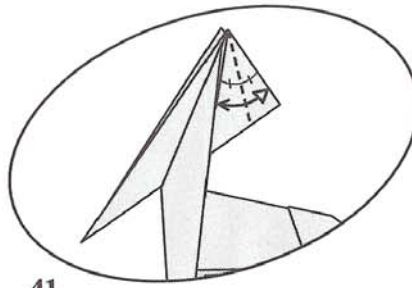

41  
Plier, déplier la  
bissectrice.

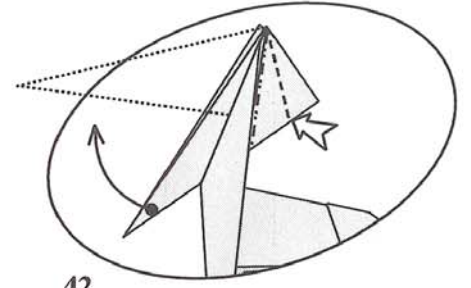

42  
Replier pour remonter  
la pointe.

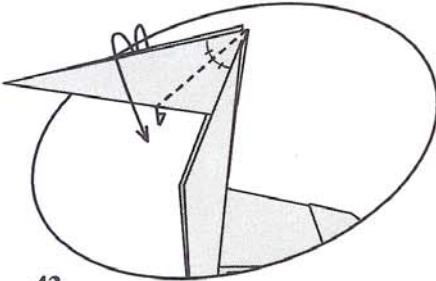

43  
Pli inversé extérieur  
sur la bissectrice.

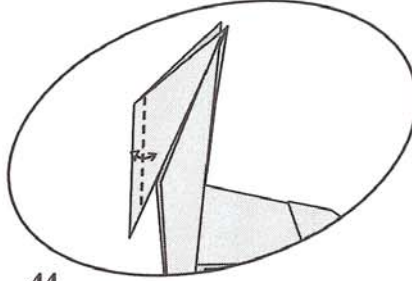

44  
Plier, déplier.

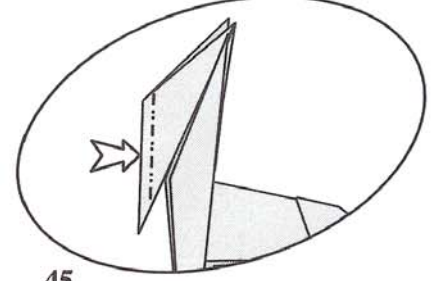

45  
Enfoncement ouvert.

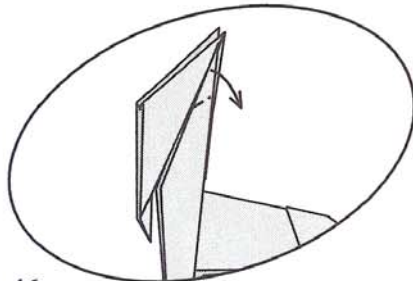

46  
Plier l'oreille vers le bas.  
Répéter derrière.

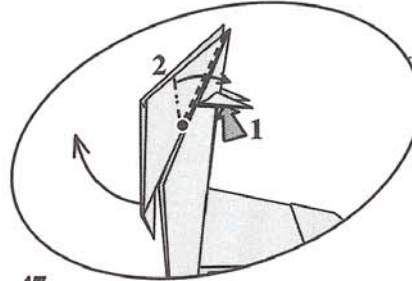

47  
1 Ouvrir l'oreille.  
2 Relever la tête.  
Répéter derrière.

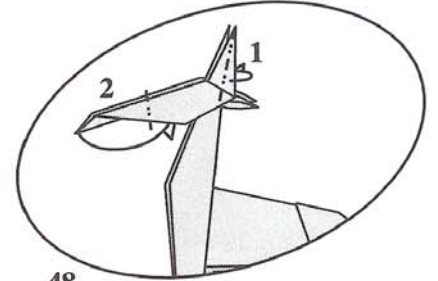

48  
1 Pli montagne.  
2 Pli inversé intérieur.  
Répéter derrière.

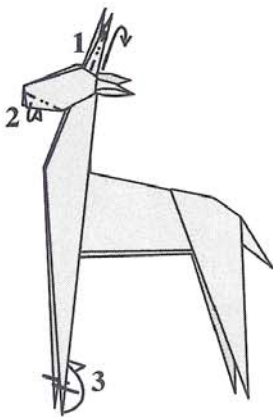

49  
1 Courber la corne.  
2 Diminuer le museau.  
3 Raccourcir la patte.  
Répéter derrière.

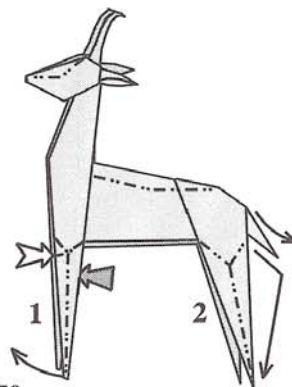

50  
1 Double oreilles de lapin.  
2 Simple oreille de lapin.  
Répéter derrière.  
Modelage final.

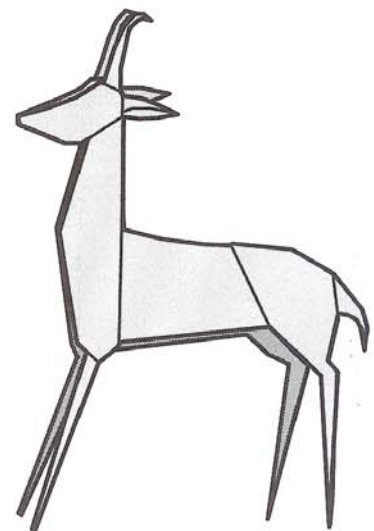

51  
GENERUK TERMINE.

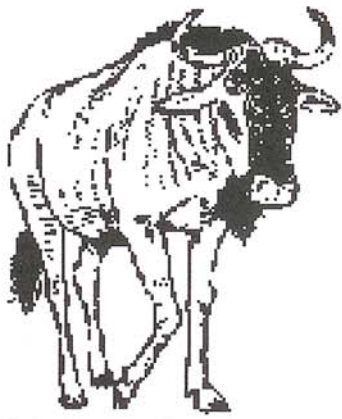

# GNOU

**Niveau de difficulté :** Complexe

**Carré couleur :** Recto

**Format :** 21 cm

**Modèle terminé :** 8 cm

**Papier :** 80 g

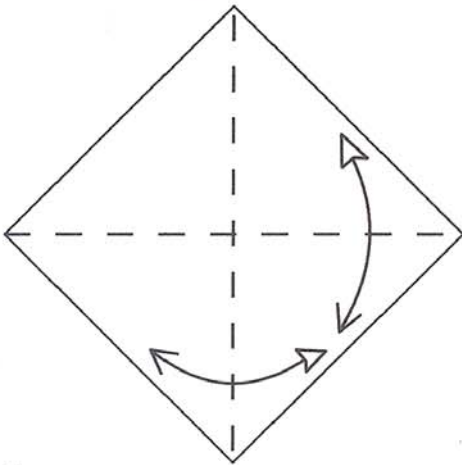

**1**  
Plier et déplier les deux diagonales.

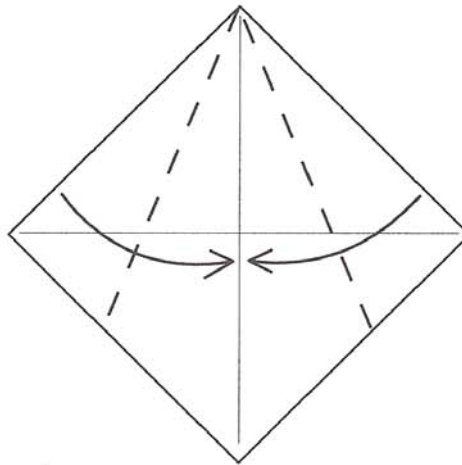

**2**  
Plier les deux côtés sur la diagonale.

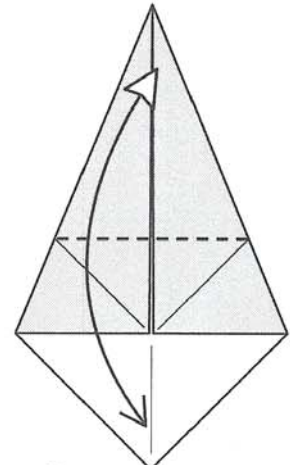

**3**  
Plier, déplier.

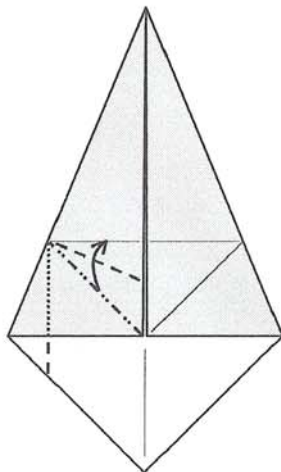

**4**  
Pli aplati à gauche.

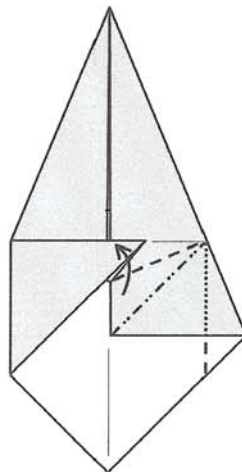

**5**  
Pli aplati à droite.

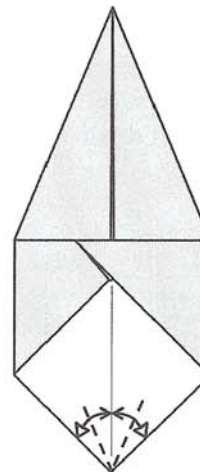

**6**  
Plier, déplier les bissectrices.

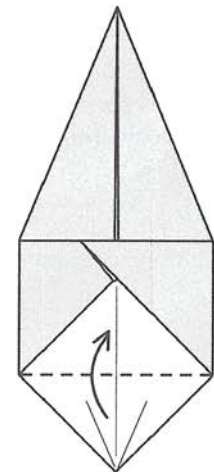

**7**  
Pli vallée.

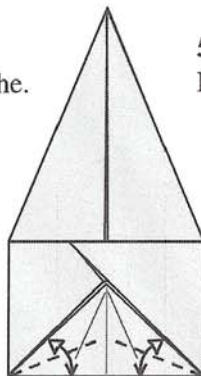

**8**  
Plier, déplier les bissectrices.

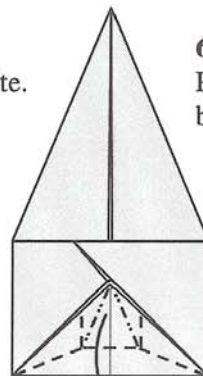

**9**  
Former la queue.

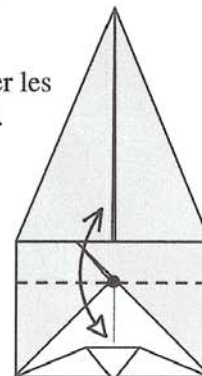

**10**  
Plier, déplier en vallée.

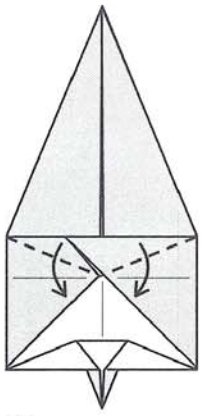

**11**  
Plier les deux pointes vers le bas.

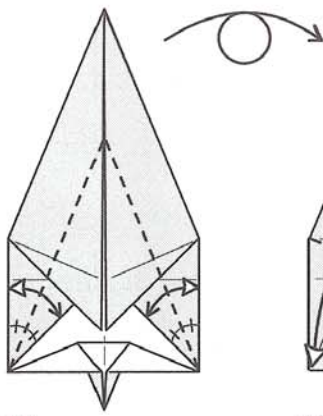

**12**  
Plier, déplier les deux bissectrices. Retourner le modèle.

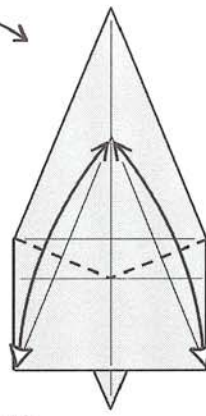

**13**  
Plier, déplier en vallée.

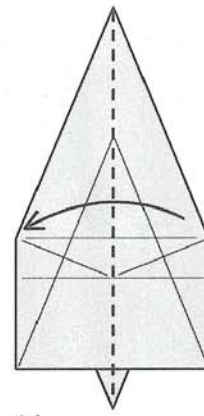

**14**  
Fermer le modèle.

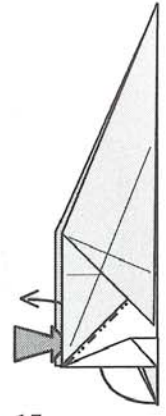

**15**  
Pli inversé intérieur.

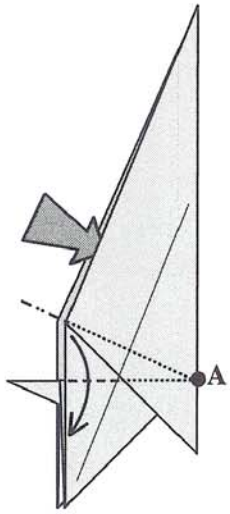

**16**  
Pli pivot sur le point A, utiliser les marques des plis faites en 10 et 13 pour construire ce pli. Répéter derrière.

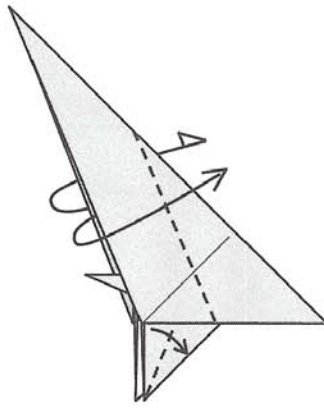

**17**  
Pli inversé extérieur pour le cou, pli vallée pour la cuisse. Répéter derrière.

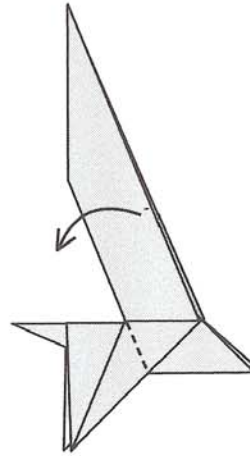

**18**  
Ecarter légèrement le volet.

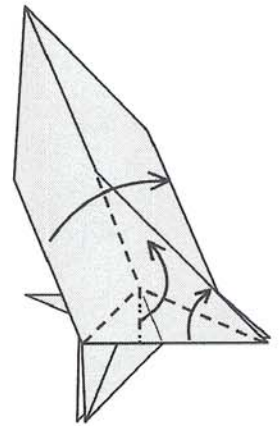

**19**  
Pli oreille de lapin.

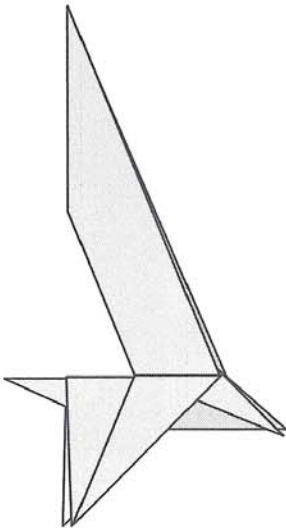

**20**  
Répéter derrière les étapes 18 et 19.

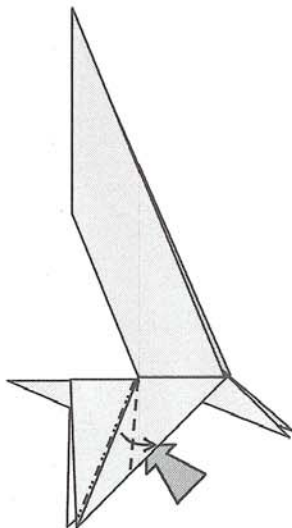

**21**  
Repli. Répéter derrière.

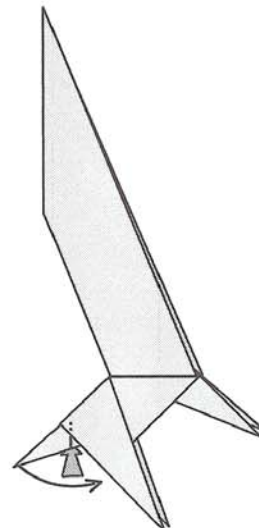

**22**  
Pli inversé intérieur.

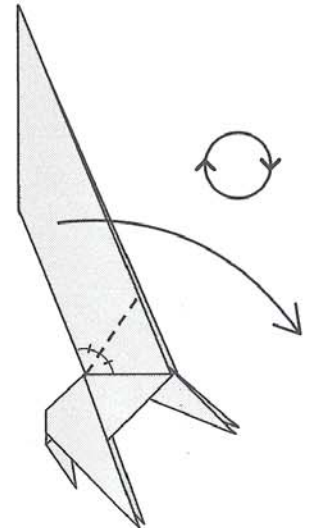

**22**  
Plier en vallée. Rotation du modèle.

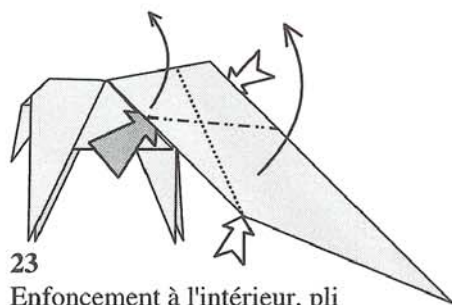

**23**  
Enfoncement à l'intérieur, pli étiré à l'extérieur.

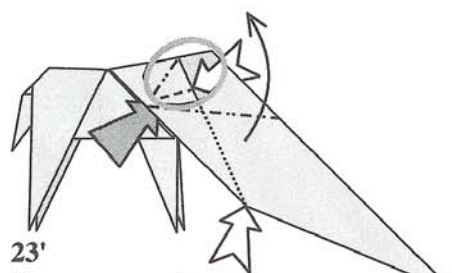

**23'**  
Vue en coupe de l'enfoncement à l'intérieur. Pli étiré à l'extérieur.

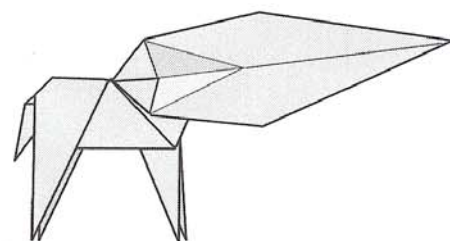

**24**  
Vue intermédiaire du pli 23.

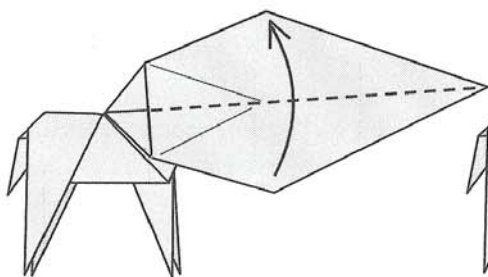

**25**  
Pli vallée.

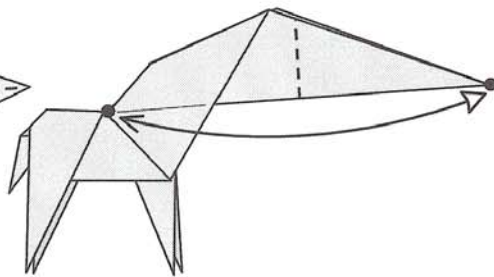

**26**  
Plier, déplier.

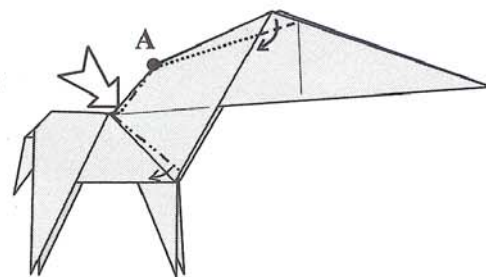

**27**  
Pli pivot sur le point A. Utiliser le pli fait en 26 pour construire ce pli. Répéter derrière.

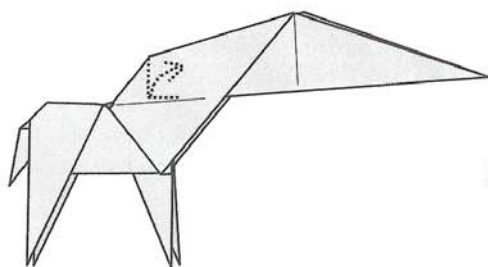

**28**  
Remonter le triangle caché entre les deux épaisseurs.

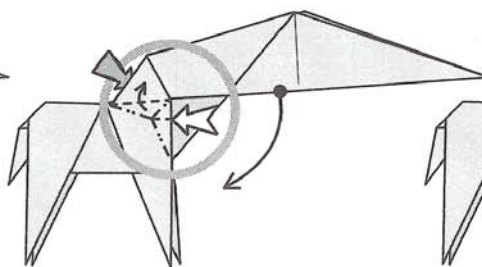

**29**  
Pour la bosse et le cou, marquer une double oreilles de lapin sur l'épaisseur indiquée par la vue en coupe tout en ...

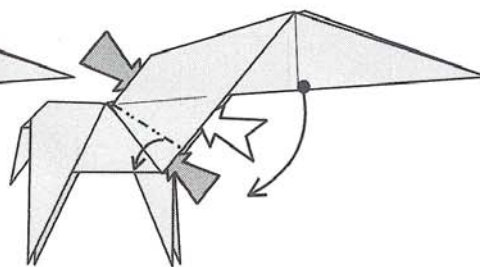

**29'**  
...pliant en montagne comme indiqué. Répéter derrière.

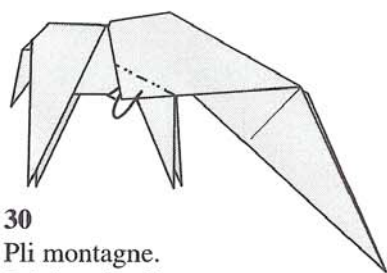

**30**  
Pli montagne. Répéter derrière.

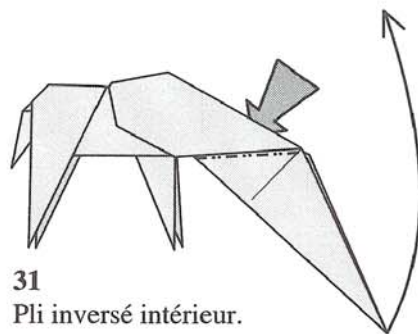

**31**  
Pli inversé intérieur.

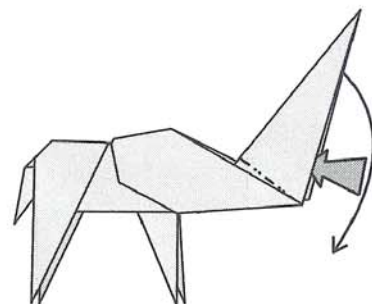

**32**  
Pli inversé intérieur. Utiliser la marque du pli faite en 26.

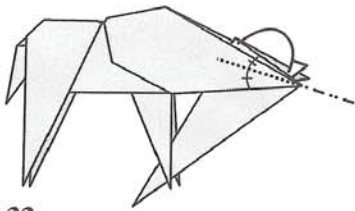

33  
Pli inversé intérieur.

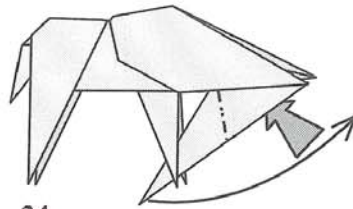

34  
Pli inversé intérieur.

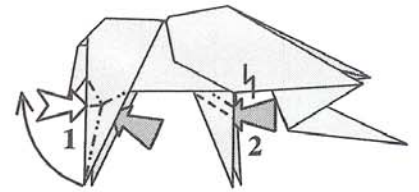

35  
1 Double oreilles de lapin pour la patte arrière  
2 Repli pour la patte avant.  
Répéter derrière.

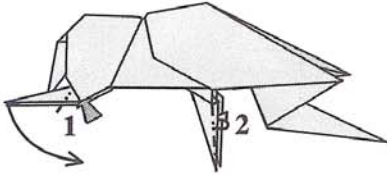

36  
1 Pli inversé pour la patte arrière.  
2 Pli montagne pour la patte avant.  
Répéter derrière.

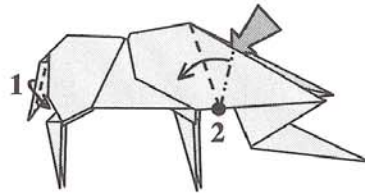

37  
1 Pli inversé extérieur pour la queue.  
2 Pli pivot pour le cou.  
Répéter derrière.

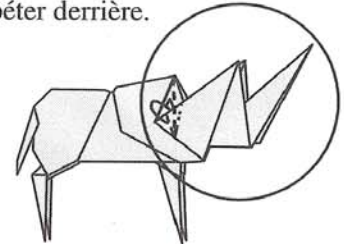

38  
Pli inversé intérieur pour le cou.  
Répéter derrière.  
Sélection de la zone de travail.

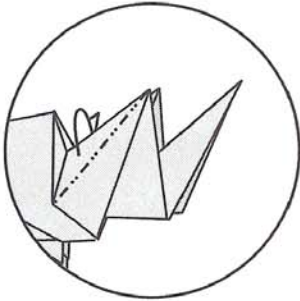

39  
Pli montagne.  
Répéter derrière.

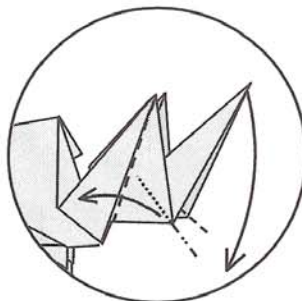

40  
Former les cornes et la tête.  
Répéter derrière.

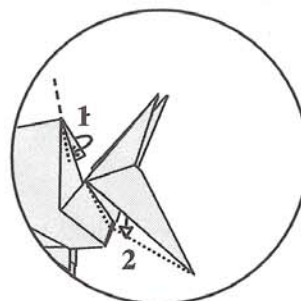

41  
1 Plier le petit rabat pour fermer la bosse.  
2 Dégager une épaisseur pour élargir la tête.  
Répéter derrière.

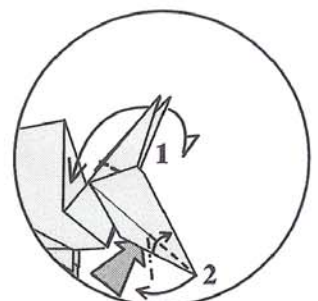

42  
1 Ecarter les cornes.  
2 Former le museau.  
Répéter derrière.

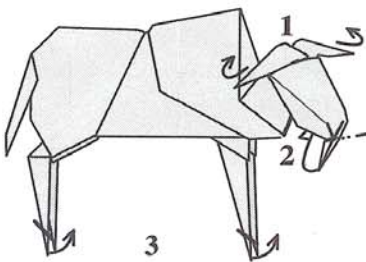

43  
1 Courber les cornes.  
2 Plier la pointe blanche dans le museau.  
3 Former les sabots.  
Répéter derrière.

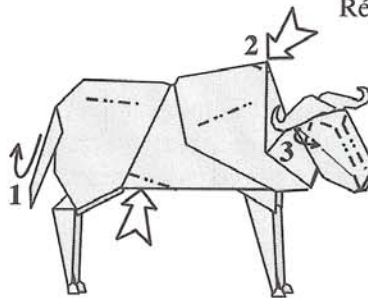

44  
1 Courber la queue.  
2 Enfoncement pour la bosse.  
3 Former l'oreille.  
Répéter derrière.  
Modelage final.

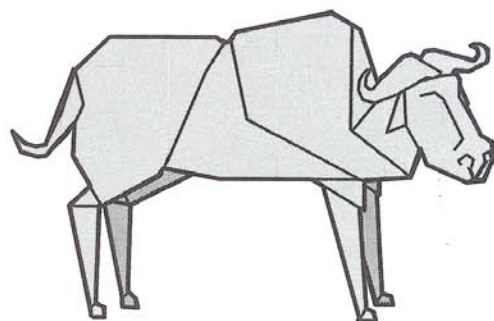

45  
GNOU TERMINE.

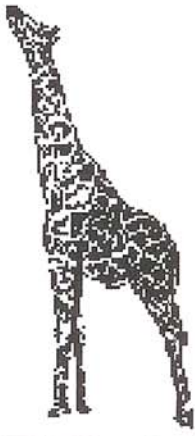

# GIRAFE

Niveau de difficulté : Intermédiaire

Carré couleur : Recto

Format : 21 cm

Modèle terminé : 11 cm

Papier : 90 g

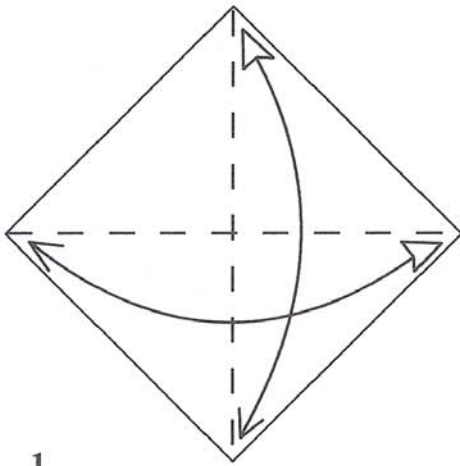

**1**  
Plier et déplier les deux diagonales.

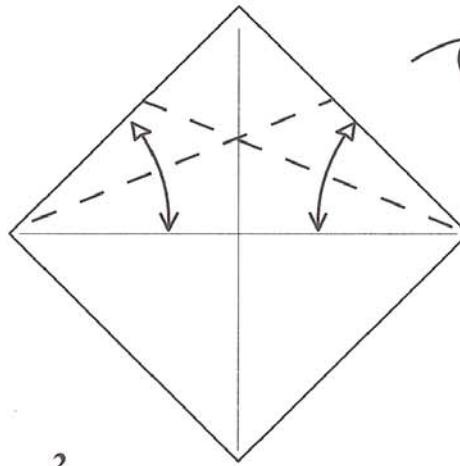

**2**  
Plier et déplier les deux bissectrices.  
Retourner le modèle.

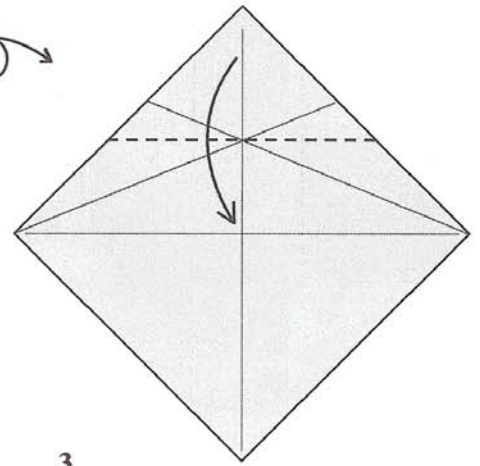

**3**  
Plier en vallée à l'intersection  
faite en 2.

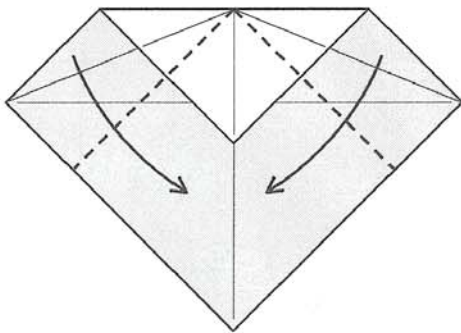

**4**  
Plis vallées.

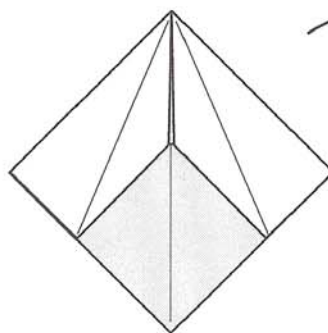

**5**  
Retourner le modèle.

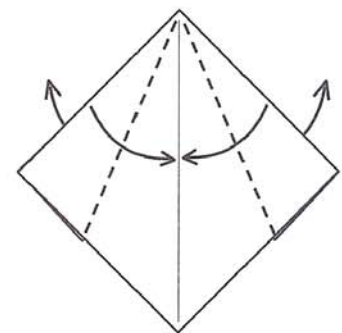

**6**  
Plier les bissectrices et dégager les deux  
volets qui se trouvent derrière.

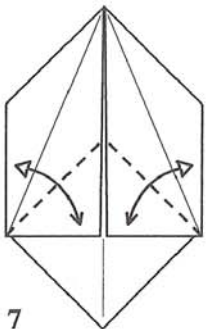

**7**  
Plier, déplier en  
vallée.

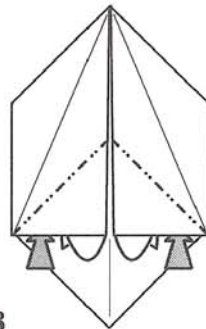

**8**  
Plis inversés intérieurs.

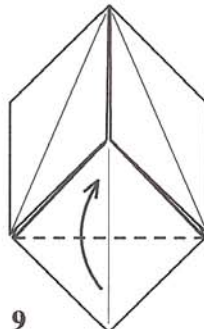

**9**  
Pli vallée.

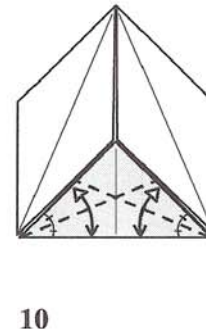

**10**  
Plier, déplier les  
bissectrices.

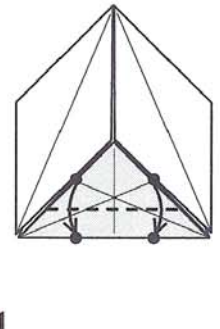

**11**  
Plier en vallée, utiliser  
les points de repère  
indiqués sur le dessin.

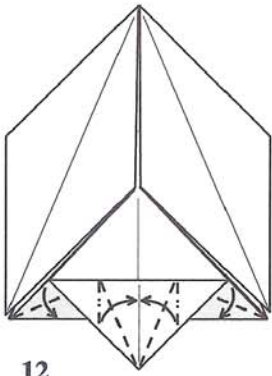

**12**  
Pliis pivots.

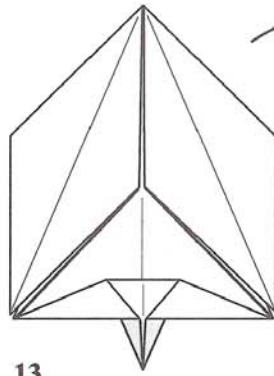

**13**  
Retourner le modèle.

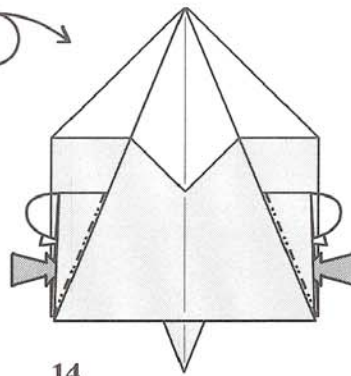

**14**  
Pliis inversés intérieurs.

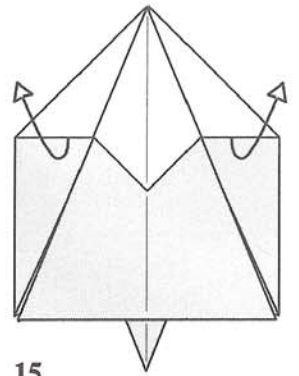

**15**  
Dégager les épaisseurs  
prisonnières.

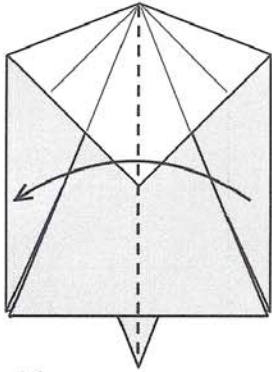

**16**  
Fermer le modèle.

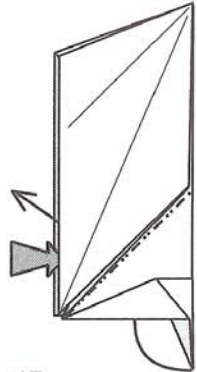

**17**  
Pli inversé intérieur.

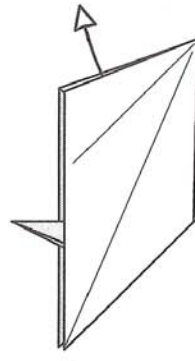

**18**  
Libérer l'épaisseur cachée.

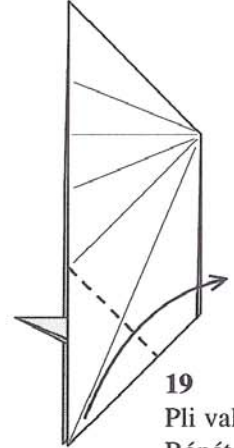

**19**  
Pli vallée.  
Répéter  
derrière.

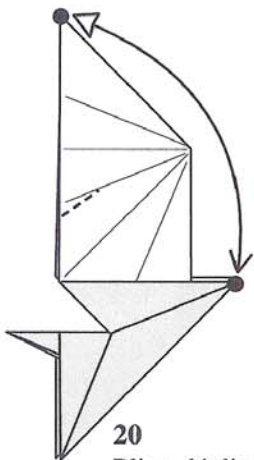

**20**  
Plier, déplier.  
Utiliser les points  
de repère.

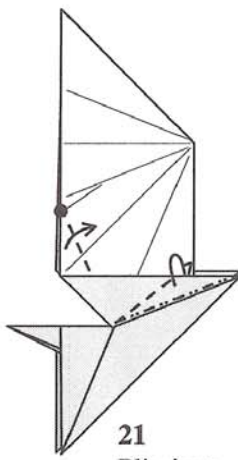

**21**  
Pli pivot.  
Utiliser la marque du  
pli faite en 20 pour  
construire ce pli.  
Répéter derrière.

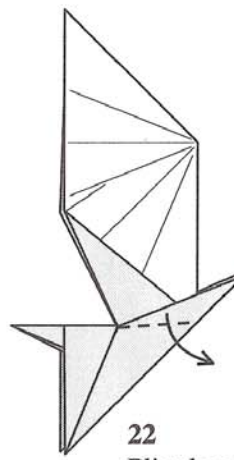

**22**  
Plier la patte vers  
le bas.  
Répéter derrière.

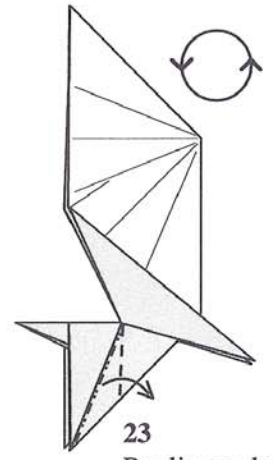

**23**  
Repli pour la  
patte arrière.  
Répéter derrière.  
Rotation du  
modèle.

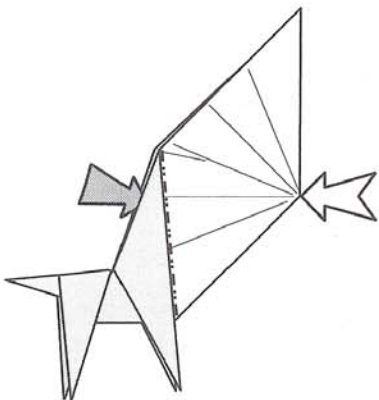

**24**  
Pli inversé intérieur.

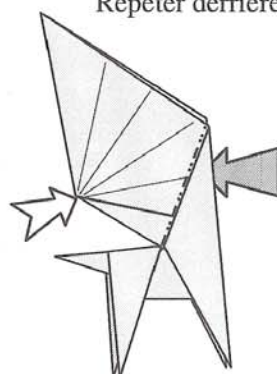

**25**  
Pli inversé intérieur.

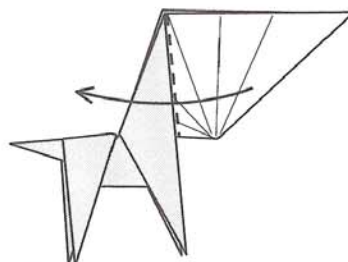

**26**  
Pli vallée.

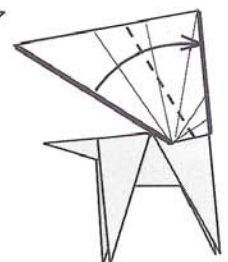

**27**  
Superposer les deux  
lignes indiquées en gras.



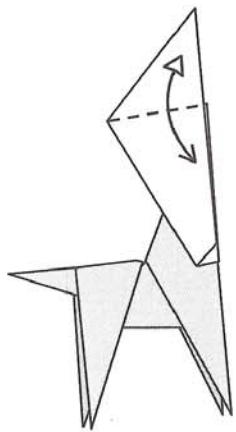

**28**  
Plier, déplier.  
**Attention** le pli vallée n'est pas une perpendiculaire.

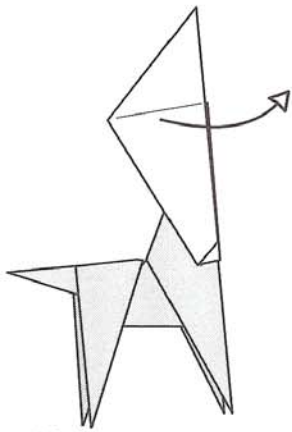

**29**  
Déplier la pointe blanche.

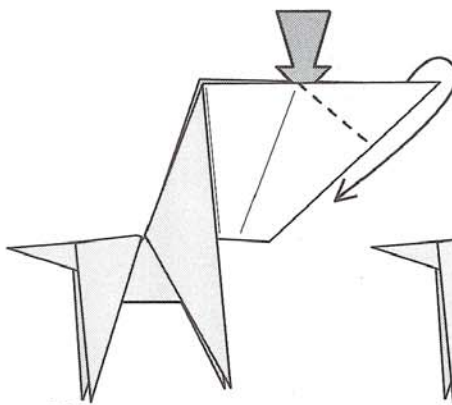

**30**  
Pli inversé extérieur.

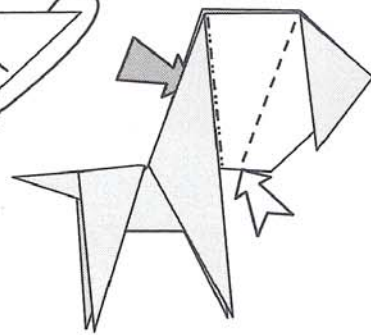

**31**  
Repli intérieur.  
Utiliser les marques des plis faites en 26 et 27 pour former ce pli.

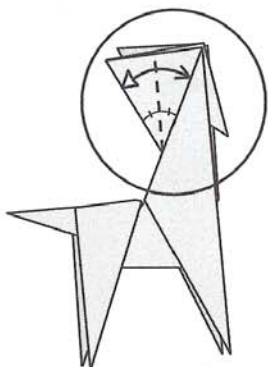

**32**  
Plier, déplier la bissectrice.  
Répéter derrière.  
Sélection de la zone de travail.

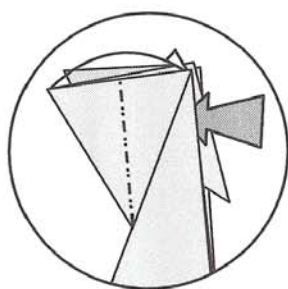

**33**  
Pli inversé intérieur.  
Répéter derrière.

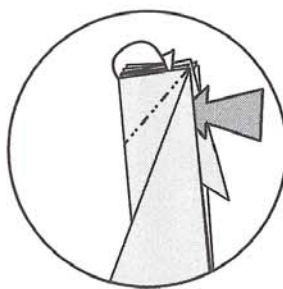

**34**  
Pli inversé intérieur.  
Répéter derrière.

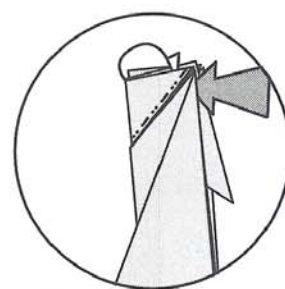

**35**  
Pli inversé intérieur.  
Répéter derrière.

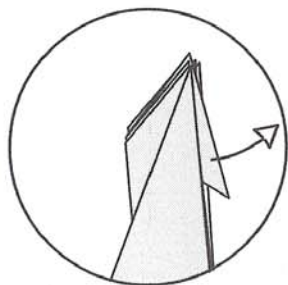

**36**  
Libérer la pointe.

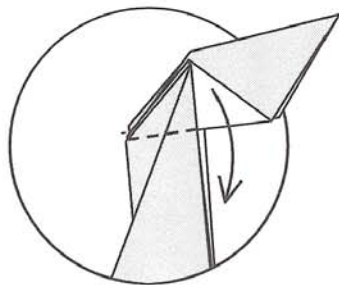

**37**  
Plier deux points vers le bas.  
Répéter derrière.

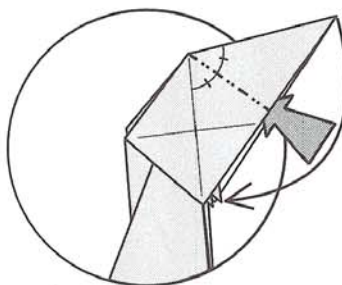

**38**  
Pli inversé sur la bissectrice.

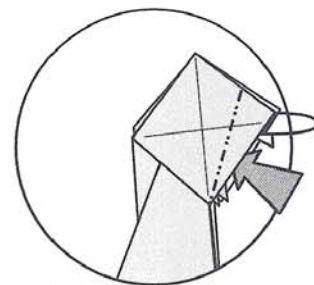

**39**  
Pli inversé intérieur.  
Répéter derrière.

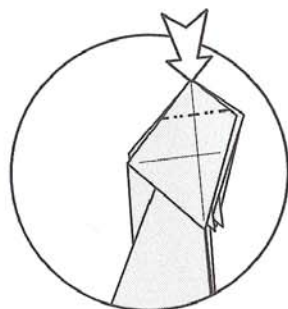

**40**  
Enfoncement ouvert.

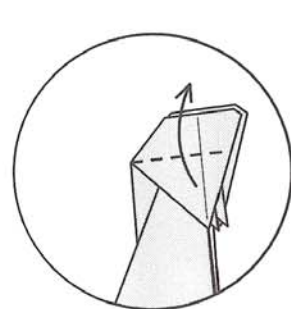

**41**  
Remonter une pointe vers le haut.  
Répéter derrière.

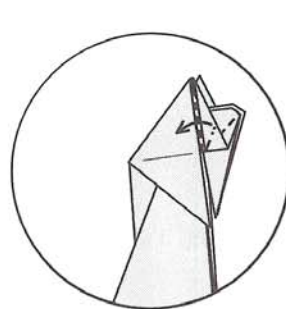

**42**  
Pli pivot.  
Répéter derrière.

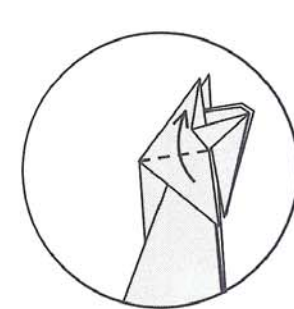

**43**  
Remonter la pointe.  
Répéter derrière.

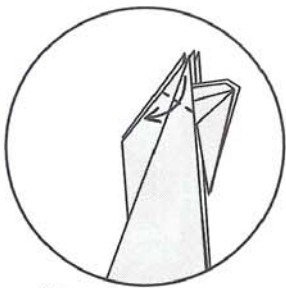

**44**  
Pli vallée.  
Répéter derrière.

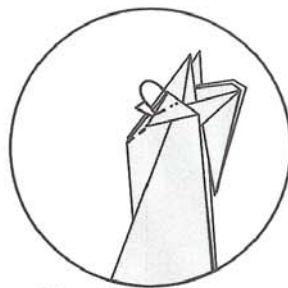

**45**  
Pli inversé.  
Répéter derrière.

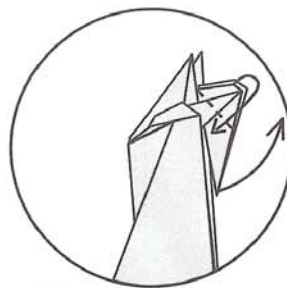

**46**  
Relever la tête.  
Répéter derrière.

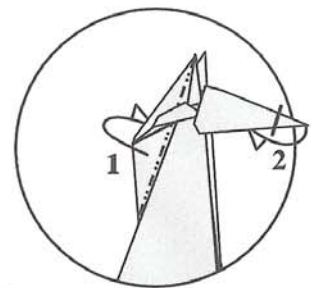

**47**  
1 Plier l'excédant de papier derrière.  
Répéter derrière.  
2 Pli inversé pour le museau.

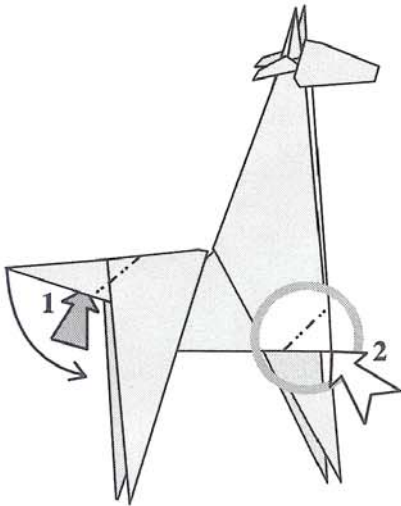

**48**  
1 Pli inversé pour la queue.  
2 Enfoncement fermé pour la partie vue en coupe du thorax.

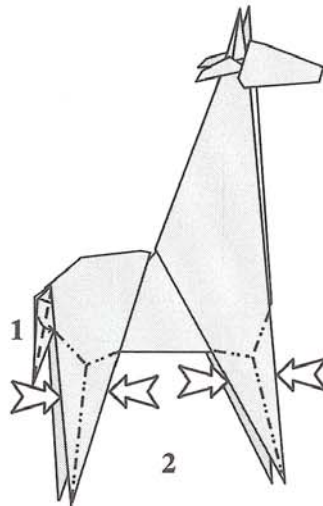

**49**  
1 Pli vallée pour la queue.  
2 Pincer les pattes pour les affiner.  
Répéter derrière.

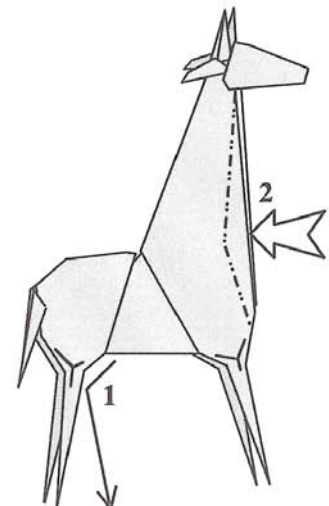

**50**  
1 Former l'articulation de la patte arrière.  
2 Modelage du cou.  
Répéter derrière.

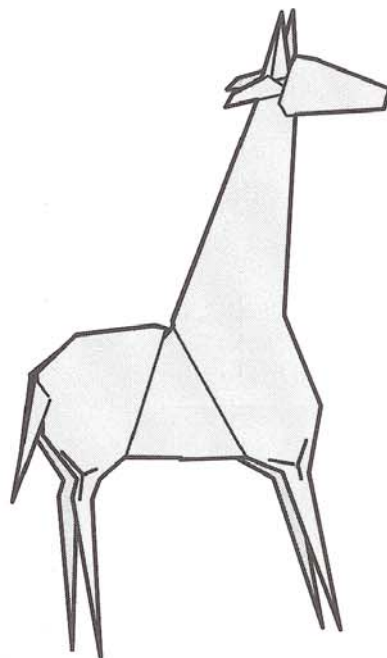

**51**  
**GIRAFE TERMINEE.**



<b>Niveau de difficulté :</b>	Intermédiaire
<b>Carré couleur :</b>	Recto
<b>Format :</b>	20 cm
<b>Modèle terminé :</b>	9 cm
<b>Papier :</b>	80 g

# SURICATE

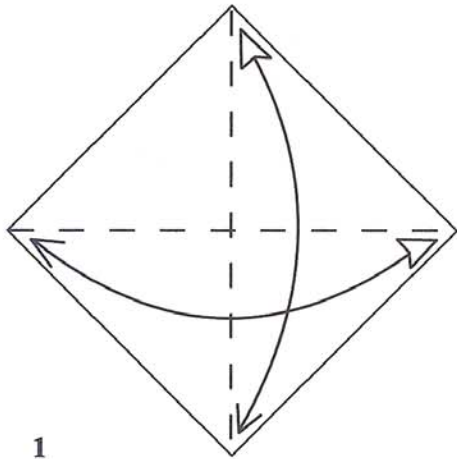

**1**  
Plier et déplier les deux diagonales.

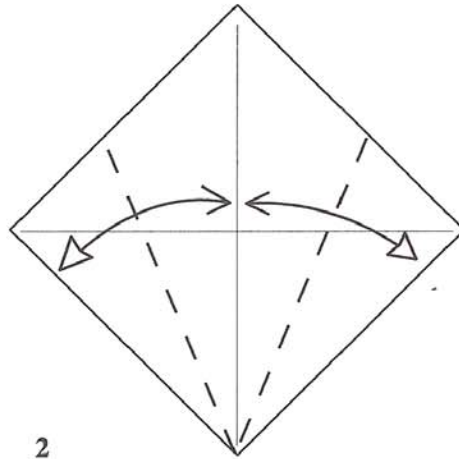

**2**  
Plier et déplier les deux côtés sur la diagonale.

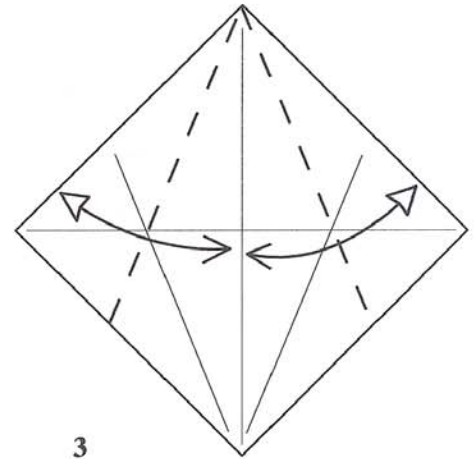

**3**  
Répéter la même opération en haut.

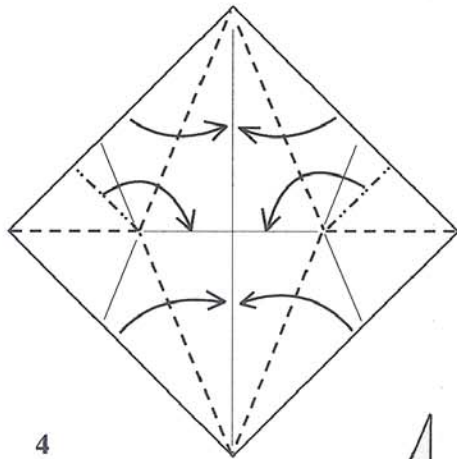

**4**  
Plier la base du poisson.

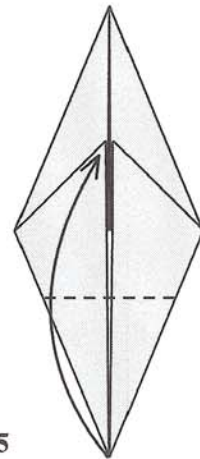

**5**  
Plier la pointe en vallée.

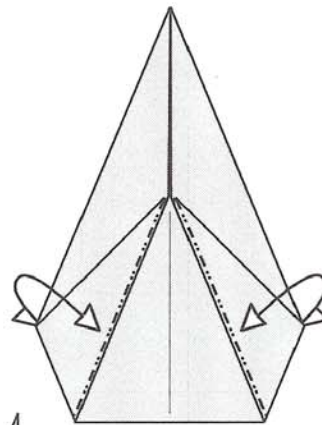

**6**  
Plier, déplier en montagne.

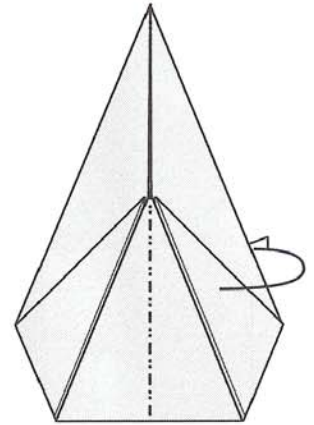

**7**  
Pli montagne.

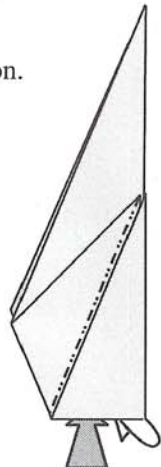

**8**  
Pli inversé intérieur.

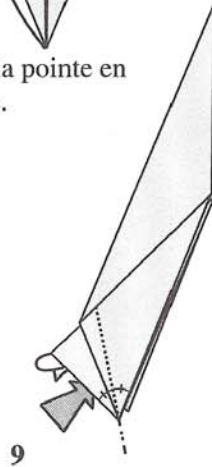

**9**  
Pli inversé intérieur.

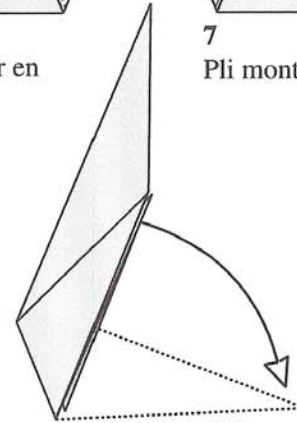

**10**  
Dégager la pointe centrale.

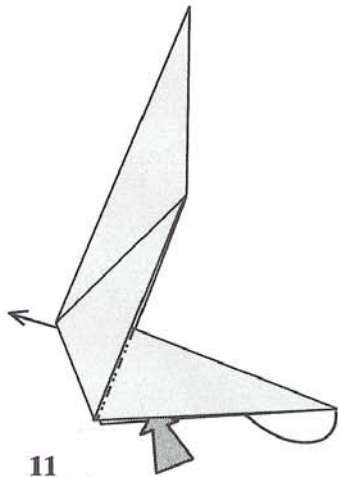

**11**  
Pli inversé intérieur.

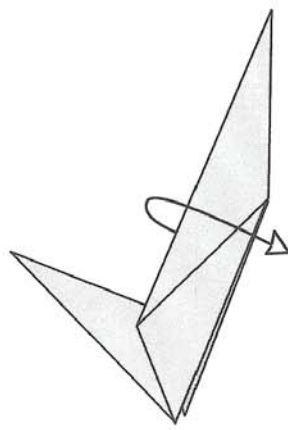

**12**  
Ecarter légèrement le premier volet.

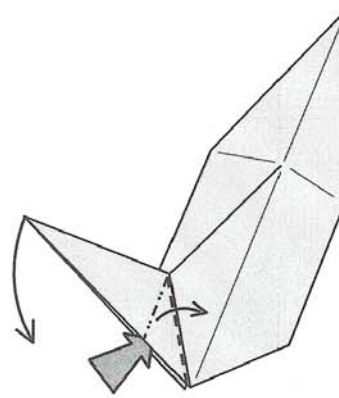

**13**  
Repli pour la queue.  
Répéter derrière.

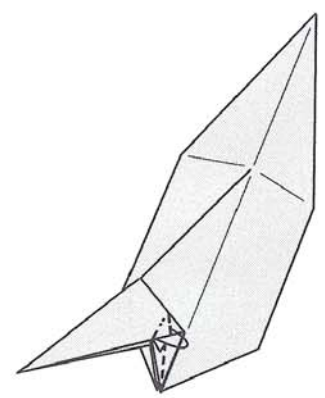

**14**  
Pli inversé.  
Répéter derrière.

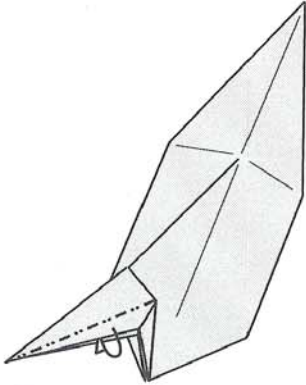

**15**  
Plier en montagne.  
Répéter derrière.

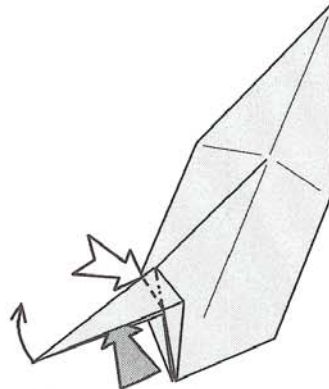

**16**  
Petit repli pour la queue.

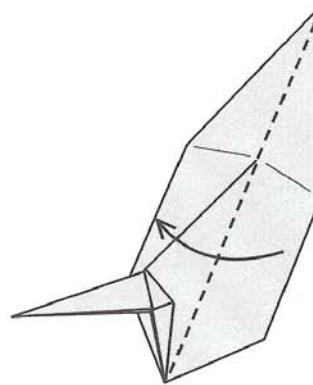

**17**  
Plier en vallée.

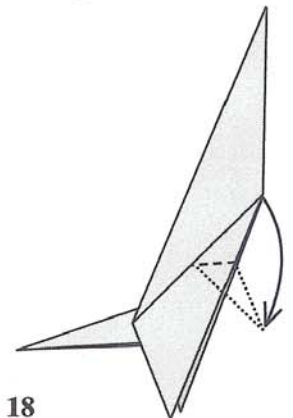

**18**  
Pli inversé intérieur pour la  
patte avant.  
Répéter derrière.

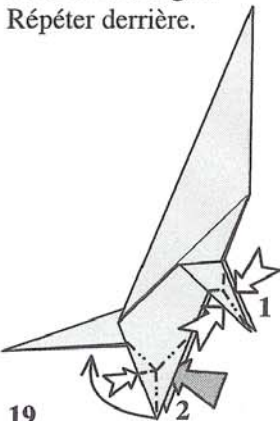

**19**  
1 Pincer la patte avant.  
2 Double oreilles de lapin  
pour la patte arrière.  
Répéter derrière.

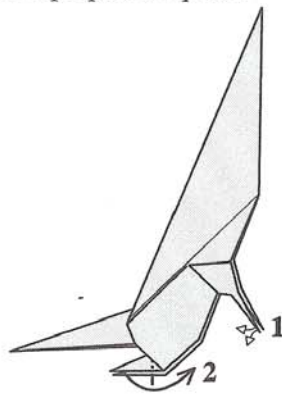

**20**  
1 Ouvrir l'extrémité de la patte avant.  
2 Pli inversé intérieur pour la  
patte arrière.  
Répéter derrière.

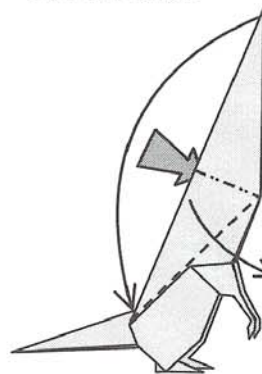

**21**  
Pli aplati.

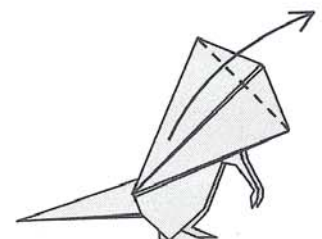

**22**  
Remonter la  
pointe.

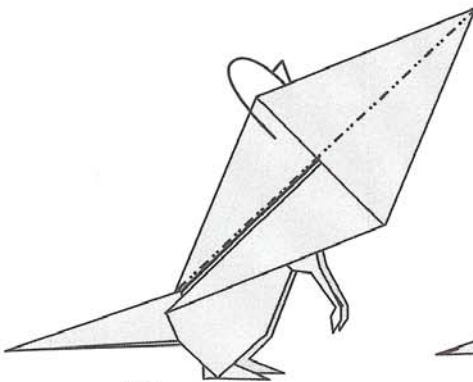

**23**  
Plier derrière.

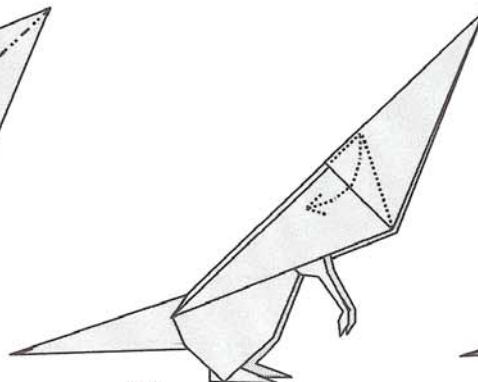

**24**  
Plier le petit triangle caché  
vers le bas.

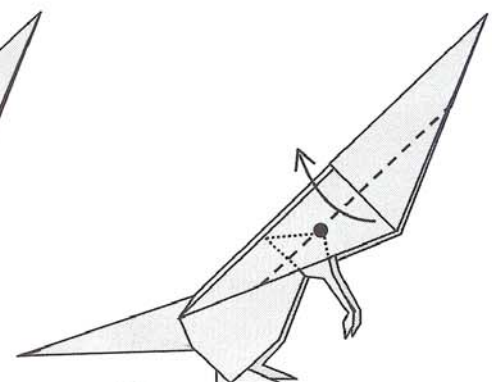

**25**  
Pli parallèle, utiliser le guide.  
Répéter derrière.

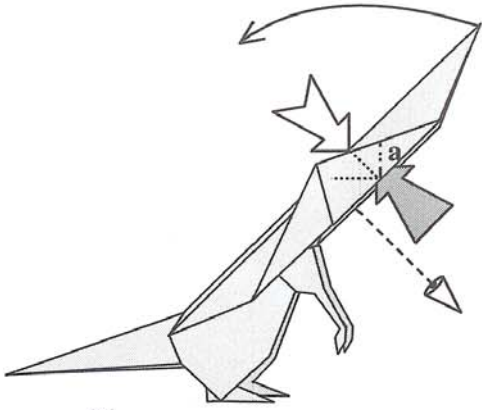

26  
Pli étiré, passer à une vue de face.

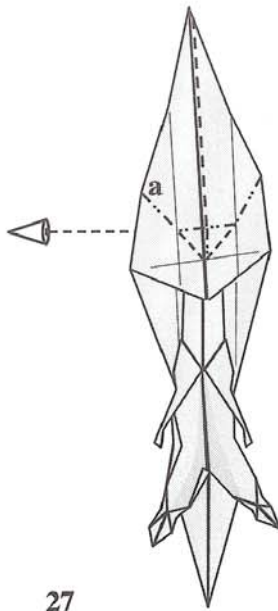

27  
Suivre ce schéma de pli.  
Passer à une vue de côté.

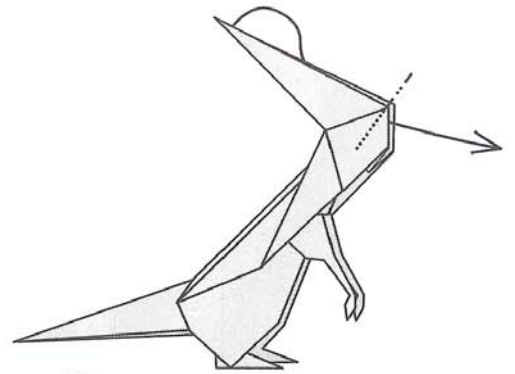

28  
Pli inversé intérieur.

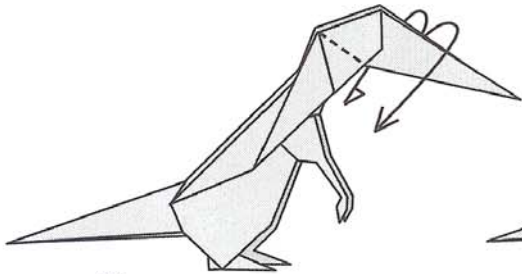

29  
Pli inversé extérieur.

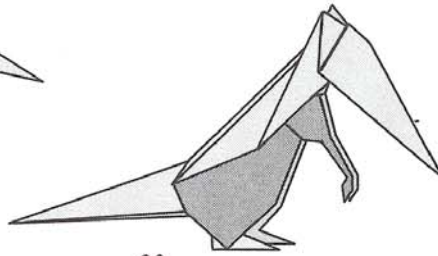

30  
Passer la zone  
foncée dessus.

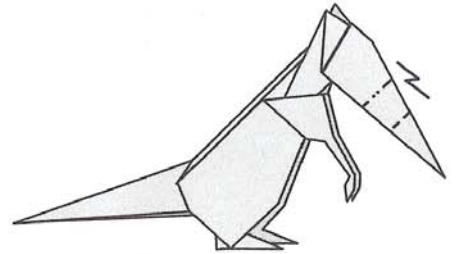

31  
Repli pour la tête.

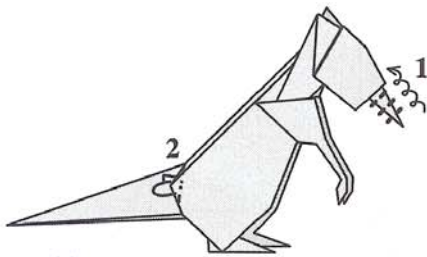

32  
1 Plis roulés pour la truffe.  
2 Pli montagne pour la cuisse.  
Répéter derrière.

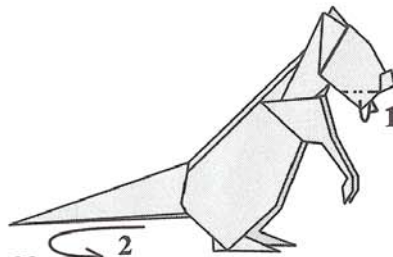

33  
1 Pli montagne pour la joue.  
Répéter derrière.  
2 Courber la queue.

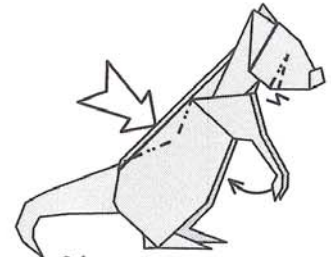

34  
Modelage final.

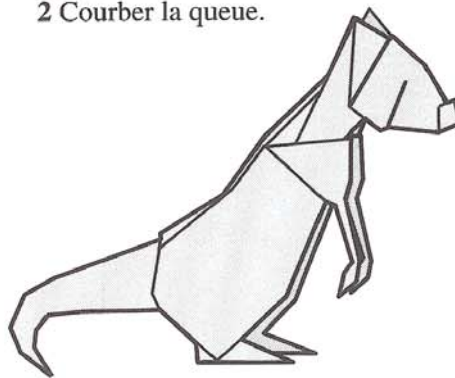

35  
SURICATE TERMINE

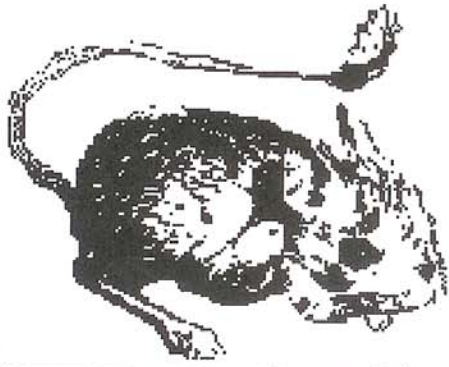

**Niveau de difficulté :** Intermédiaire

**Carré couleur :** Recto

**Format :** 21 cm

**Modèle terminé :** 5 cm

**Papier :** 80 g

# GERBOISE

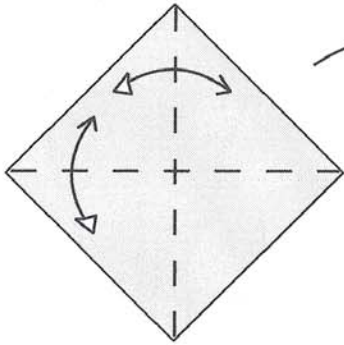

**1**  
Plier, déplier.  
Retourner le modèle.

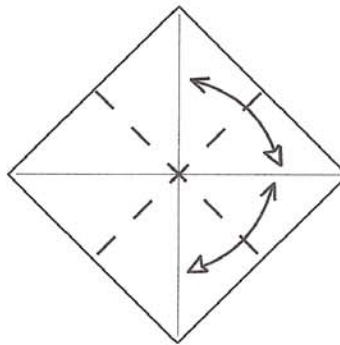

**2**  
Plier, déplier.

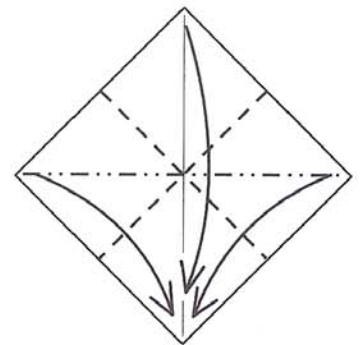

**3**  
Plier la base préliminaire.

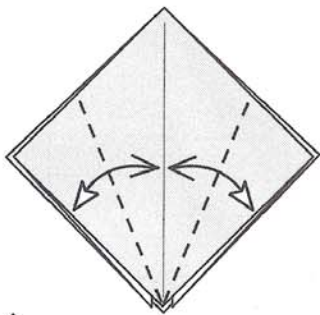

**4**  
Plier déplier.  
Répéter derrière.

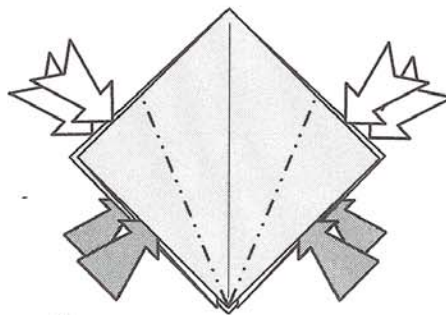

**5**  
Former la base de l'oiseau.

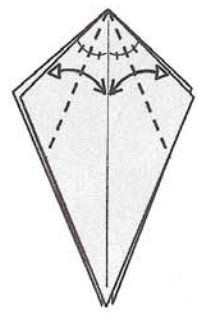

**6**  
Plier, déplier les bissectrices.

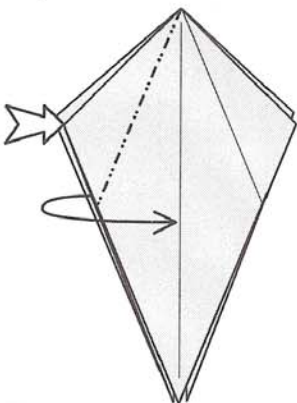

**7**  
Enfoncement étiré sur le coin.

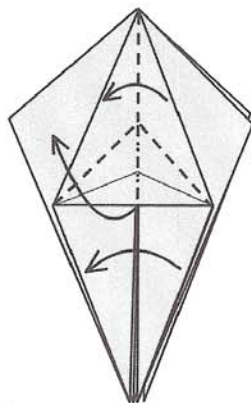

**8**  
Relever le triangle tout en faisant passer un volet vers la gauche.

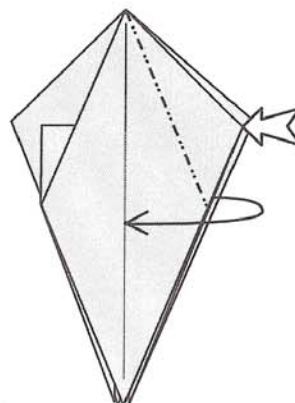

**9**  
Répéter les opérations 7 et 8 sur le coin à droite.

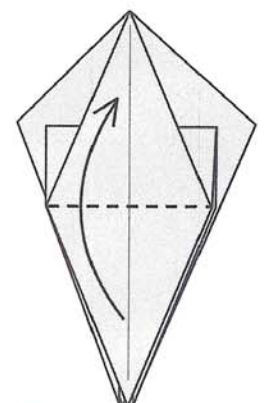

**10**  
Remonter la pointe.

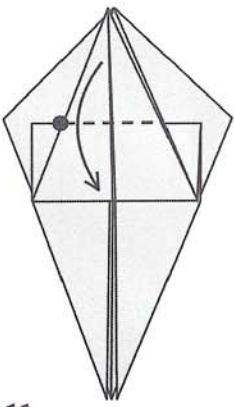

**11**  
Pli vallée. Le point indique le repère pour marquer ce pli.

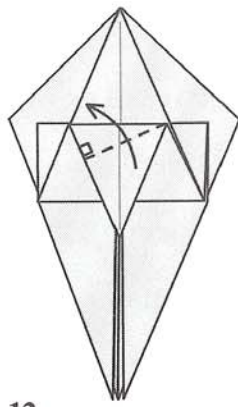

**12**  
Plier une perpendiculaire.

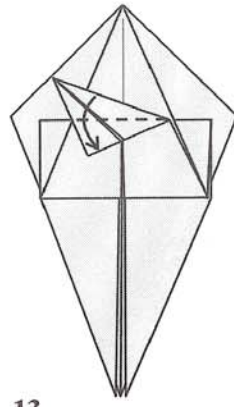

**13**  
Pli vallée.

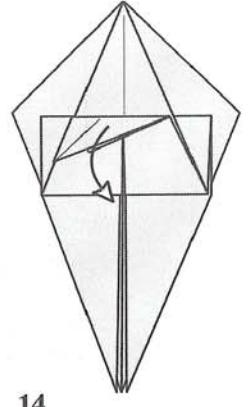

**14**  
Déplier.

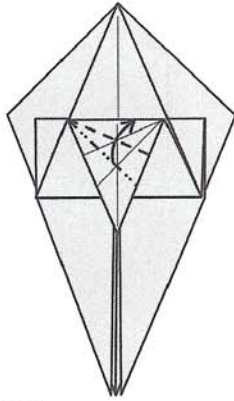

**15**  
Répéter les étapes de 12 à 14 dans l'autre sens.

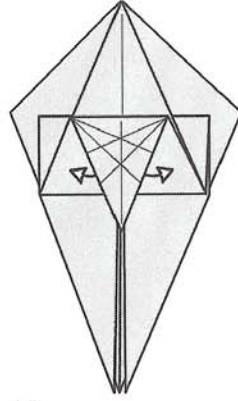

**16**  
Utiliser les marques des plis pour sortir ces épaisseurs.

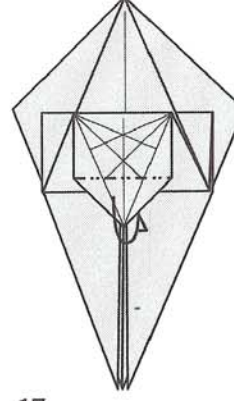

**17**  
Plier derrière.

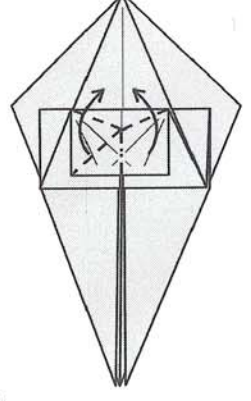

**18**  
Former un pli oreille de lapin en utilisant les marques des plis existantes.

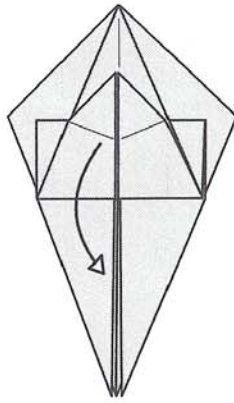

**19**  
Descendre la pointe.

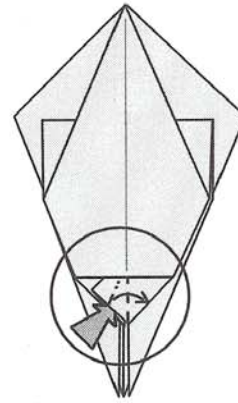

**20**  
Pli aplati.  
Sélection de la zone de travail.

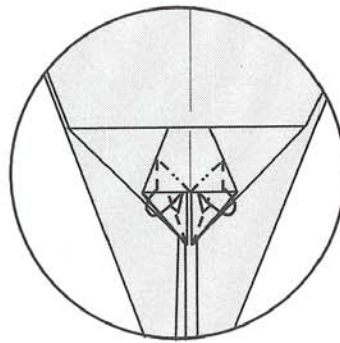

**21**  
Pli pétale.

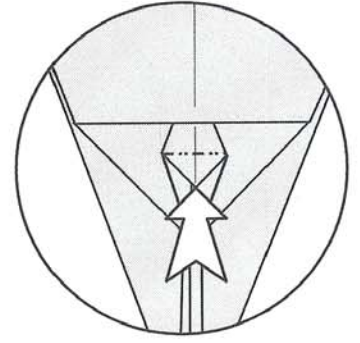

**22**  
Pli inversé sur le triangle.

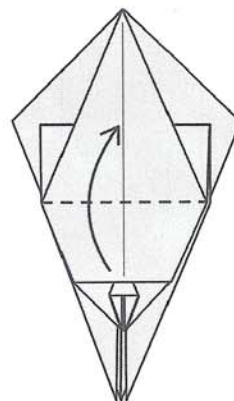

**23**  
Remonter la pointe.

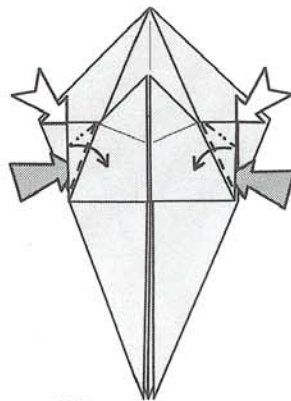

**24**  
Plis aplatis.

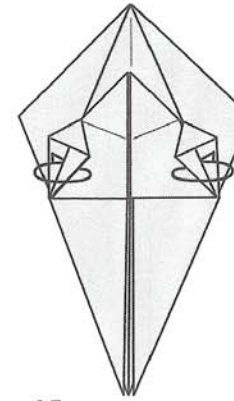

**25**  
Plier les triangles dedans.

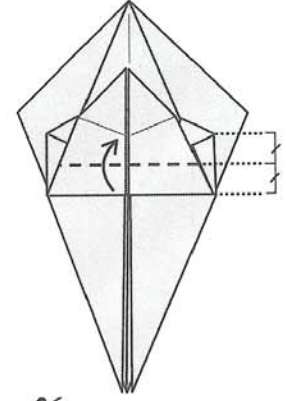

**26**  
Pli vallée.

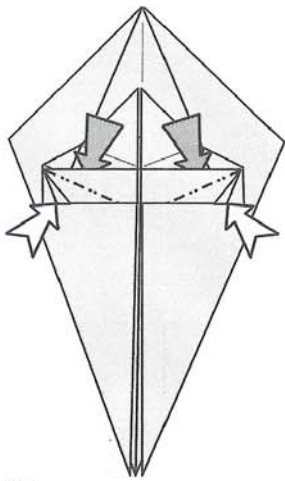

27  
Plis inversés intérieurs.

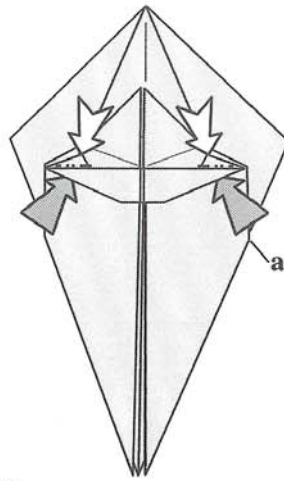

28  
Plis inversés intérieurs.  
Retourner le modèle.  
Le point a est une indication  
pour l'étape 30.

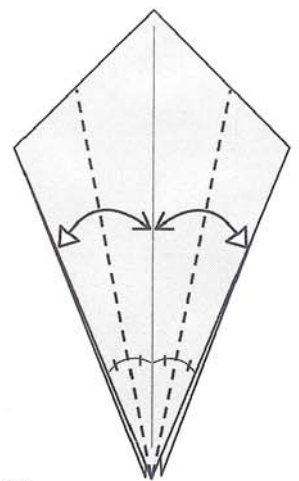
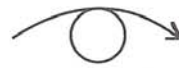

29  
Plier, déplier les bissectrices.

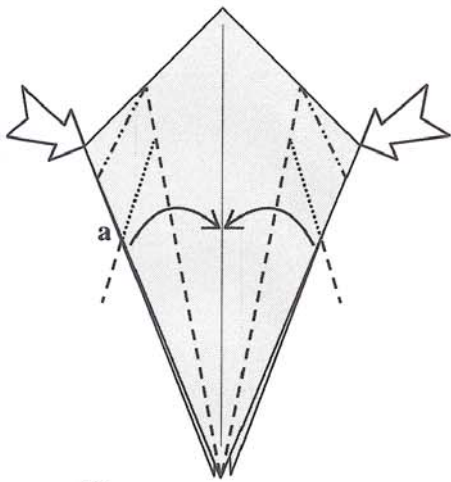

30  
Enfoncement étiré sur  
les deux coins.  
Utiliser le point a pour  
construire ce pli.

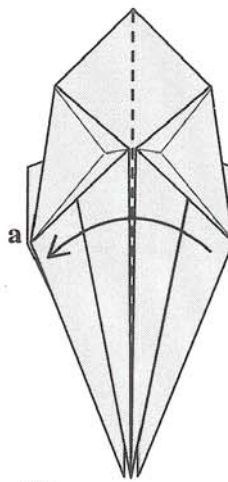

31  
Fermer le modèle.

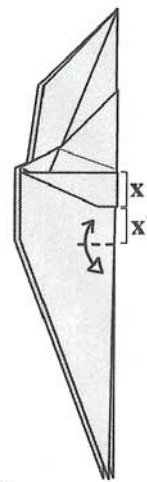

32  
Plier, déplier en vallée en  
respectant la distance x'.

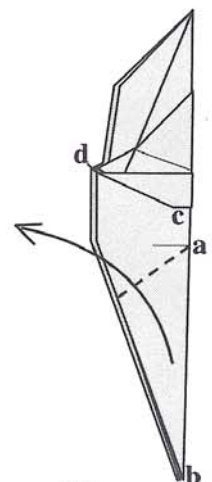

33  
Pli vallée.  
La ligne a b doit être  
parallèle à la ligne c d.  
Répéter derrière.

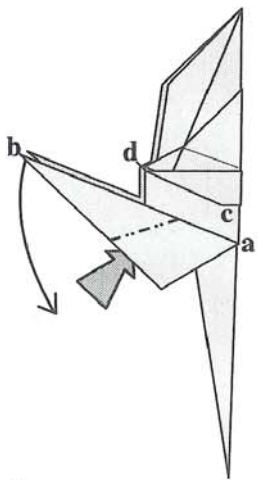

34  
Pli inversé intérieur pour  
la patte.  
Répéter derrière.

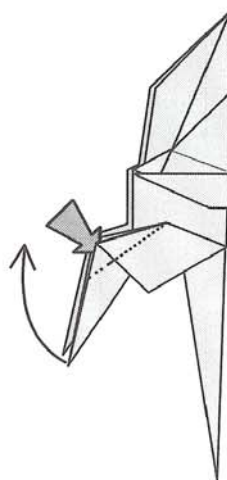

35  
Pli inversé intérieur pour  
l'articulation de la patte.  
Répéter derrière.

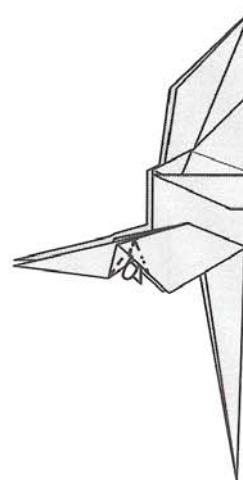

36  
Pli aplati pour la cuisse.  
Répéter à l'intérieur.  
Répéter derrière.

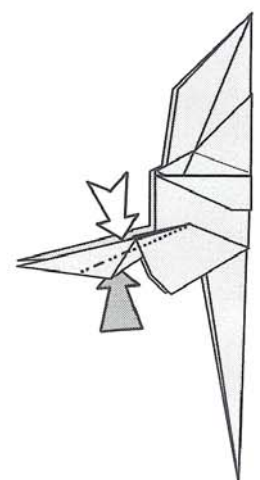

37  
Pli inversé intérieur pour  
la patte.  
Répéter derrière.



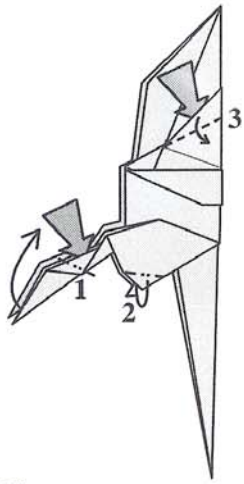

- 38**  
 1 Pli inversé intérieur pour la patte.  
 2 Pli montagne pour la cuisse.  
 3 Ouvrir l'oreille.  
 Répéter derrière.

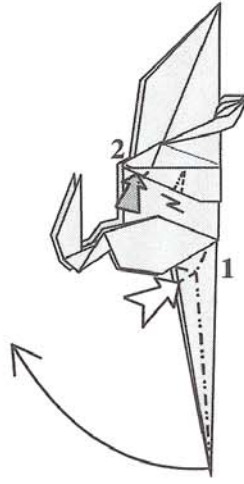

- 39**  
 1 Double oreilles de lapin pour la queue.  
 2 Former la patte avant.  
 Répéter derrière.

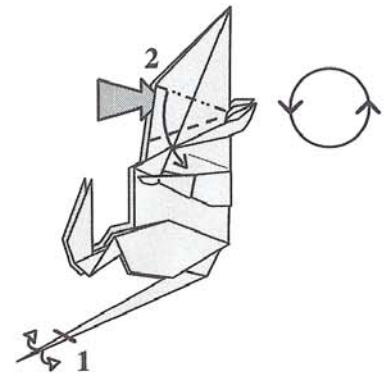

- 40**  
 1 Former le toupet de la queue.  
 2 Repli pour la tête.  
 Répéter derrière.  
 Rotation du modèle.

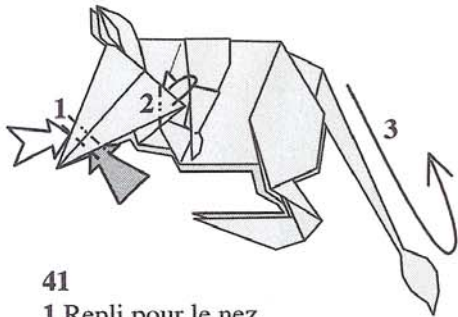

- 41**  
 1 Repli pour le nez  
 2 Pli montagne pour la joue.  
 Répéter derrière.  
 3 Courber la queue.

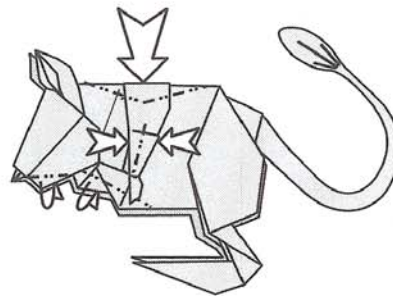

- 42**  
 Modelage final.

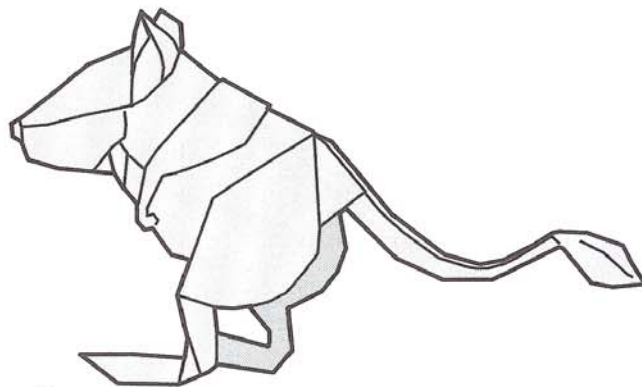

- 43**  
**GERBOISE TERMINEE**



**Niveau de difficulté :** Moyen

**Carré couleur :** Recto

**Format :** 31 cm

**Modèle terminé :** 5,5 cm

**Papier :** 60 g

# PHACOCHERE

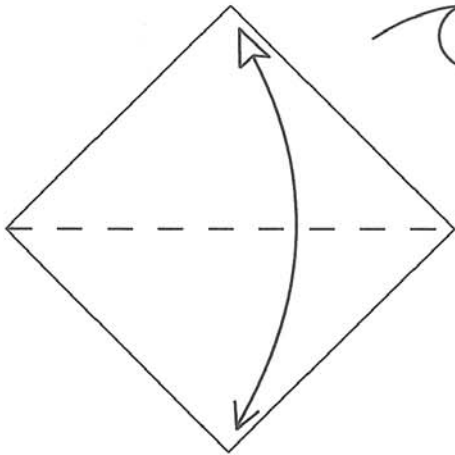

**1**  
Plier et déplier la diagonale.  
Retourner le modèle.

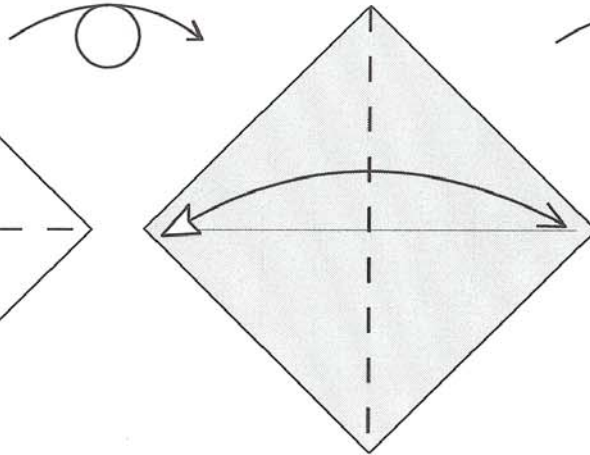

**2**  
Plier et déplier la diagonale.  
Retourner le modèle.

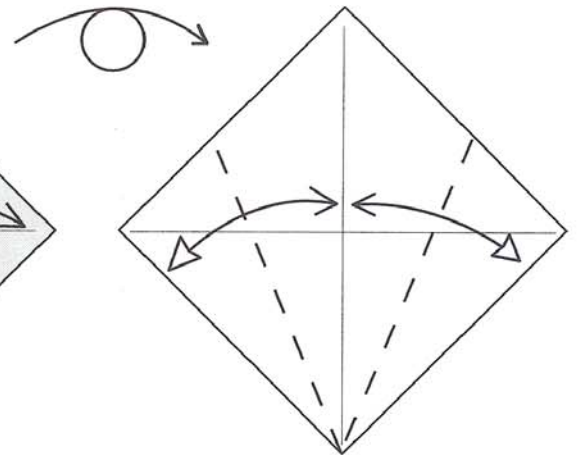

**3**  
Plier et déplier les deux côtés sur la diagonale.

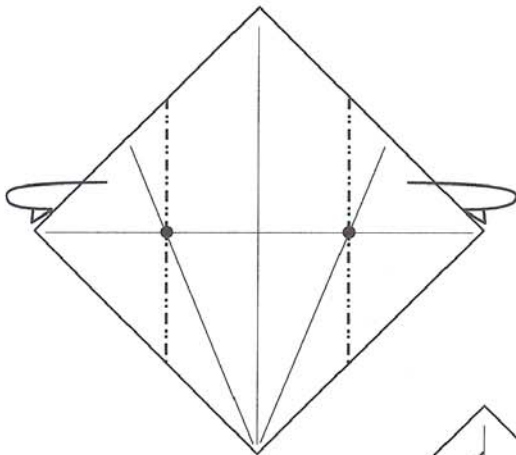

**4**  
Plier derrière.

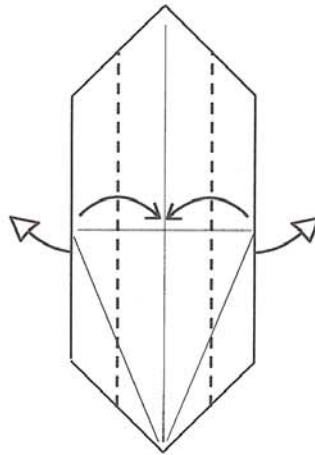

**5**  
Plis vallées.

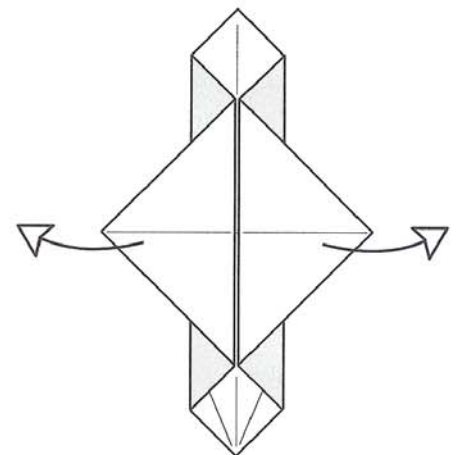

**6**  
Déplier.

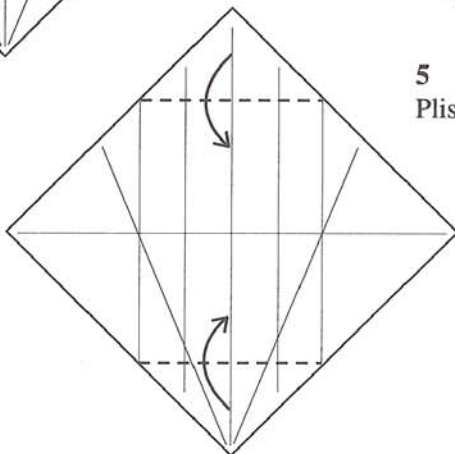

**7**  
Plis vallées.

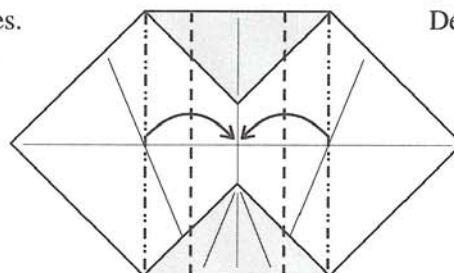

**8**  
Reformer les plis.

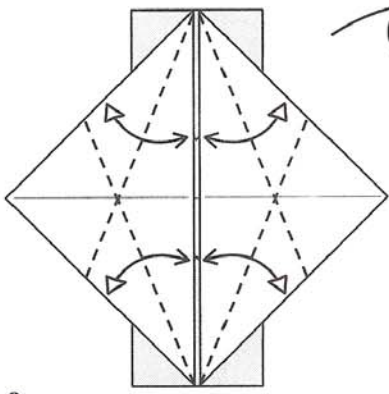

**9**  
Plier, déplier.  
Retourner le modèle.

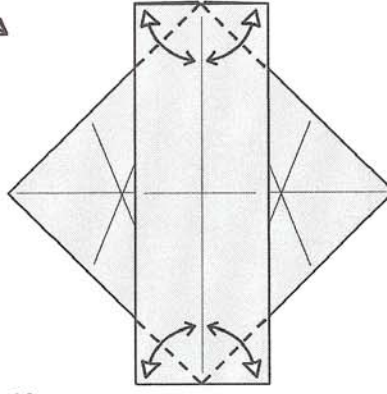

**10**  
Plier, déplier.

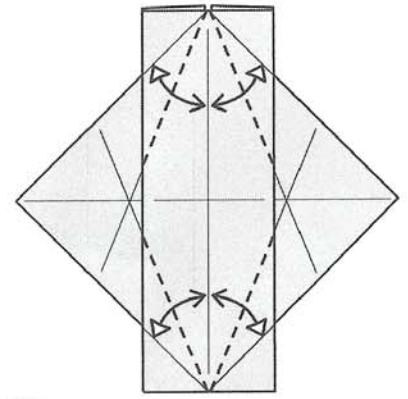

**11**  
Plier, déplier.

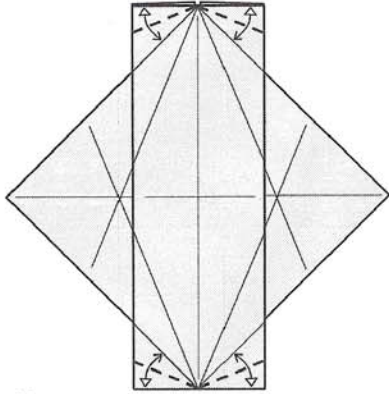

**12**  
Plier, déplier.

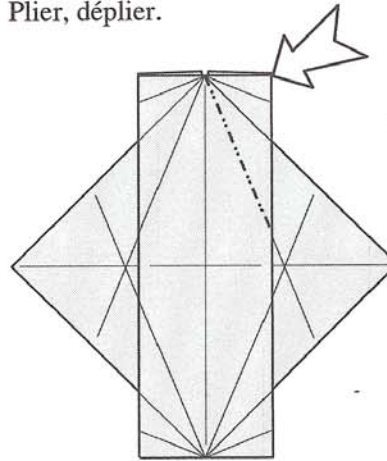

**13**  
Pli inversé intérieur.  
Retourner le modèle.

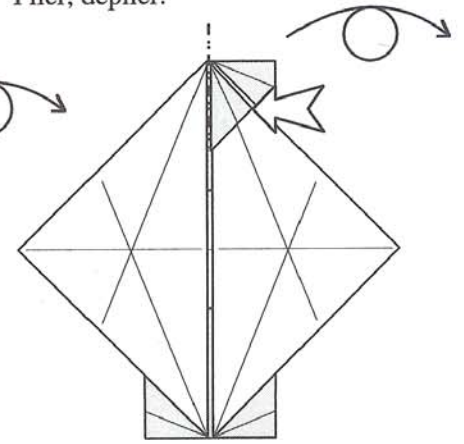

**14**  
Pli inversé intérieur.  
Retourner le modèle.

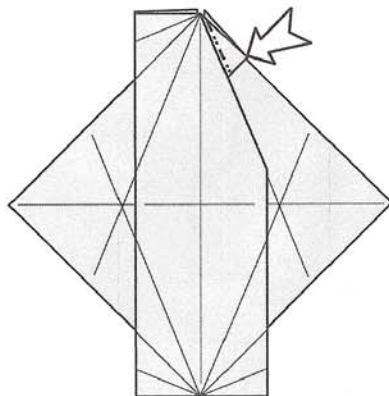

**15**  
Pli inversé intérieur.

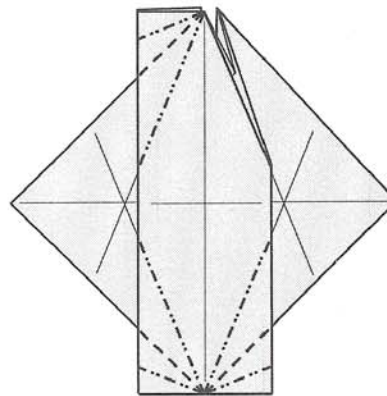

**16**  
Répéter les opérations de 13 à 15 sur les trois autres coins.

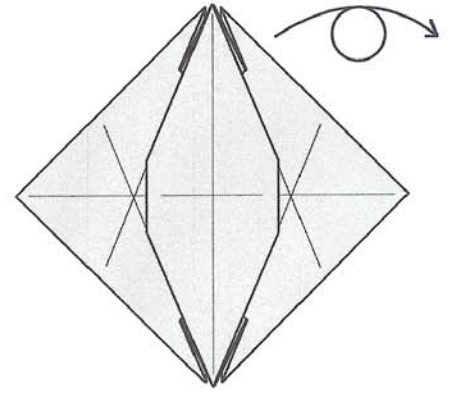

**17**  
Retourner le modèle.

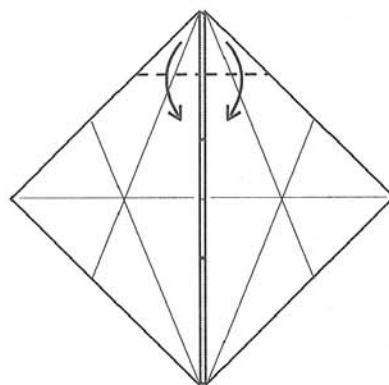

**18**  
Plier les pointes vers le bas.

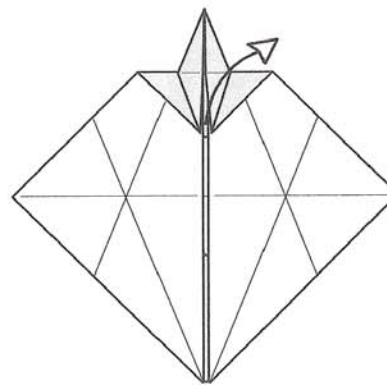

**19**  
Libérer l'épaisseur.

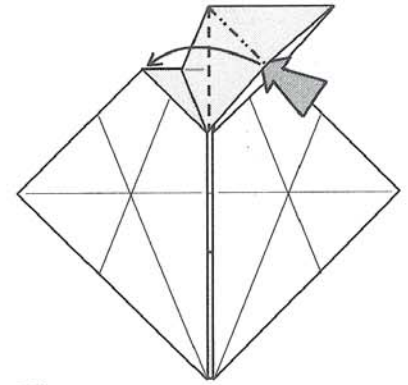

**20**  
Pli aplati.

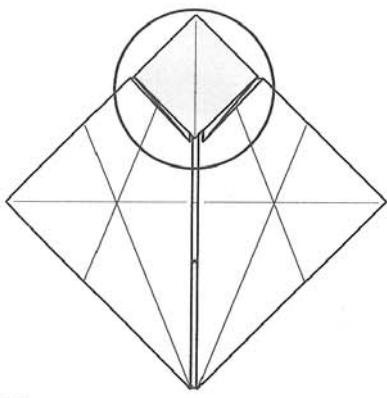

21  
Sélection de la zone de travail.

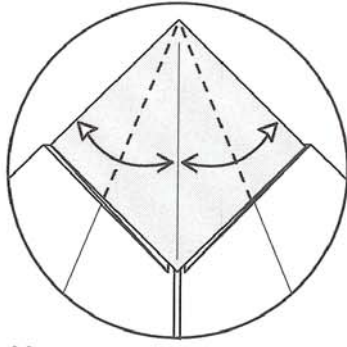

22  
Plier, déplier.

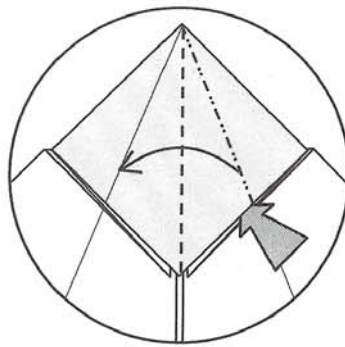

23  
Pli aplati.

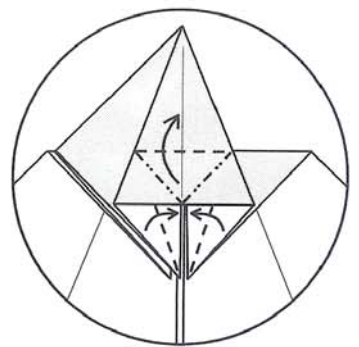

24  
Pli pétale.

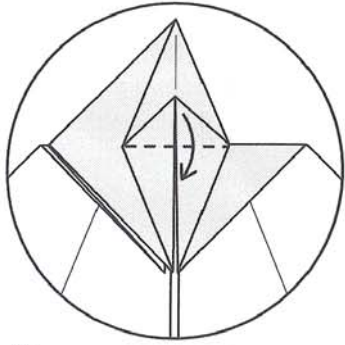

25  
Pli vallée.

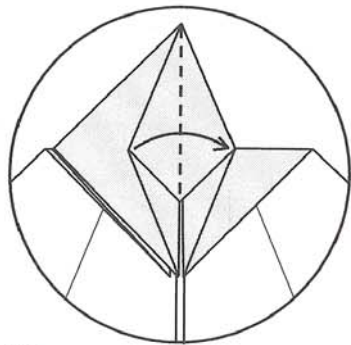

26  
Pli vallée.

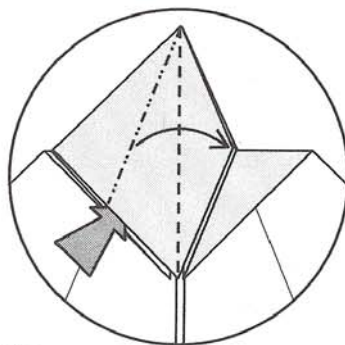

27  
Répéter les opérations de 23 à  
26 sur la partie gauche.

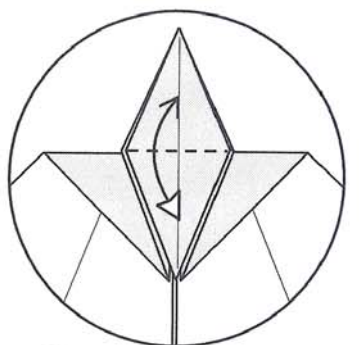

28  
Plier, déplier.

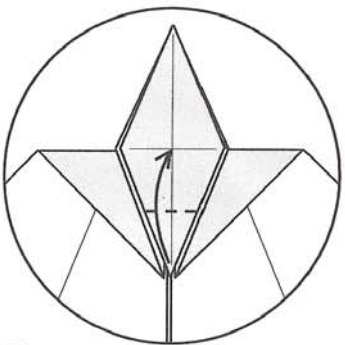

29  
Pli vallée.

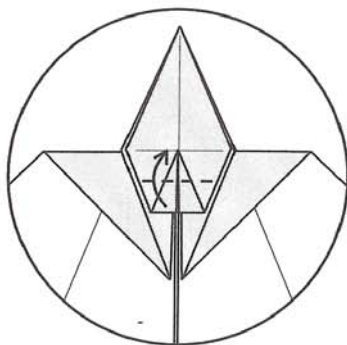

30  
Pli vallée.

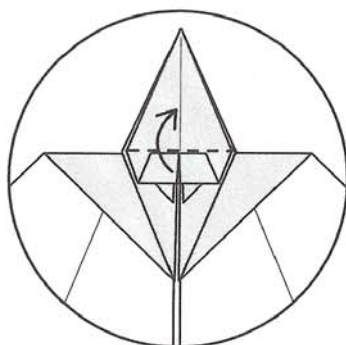

31  
Pli vallée.

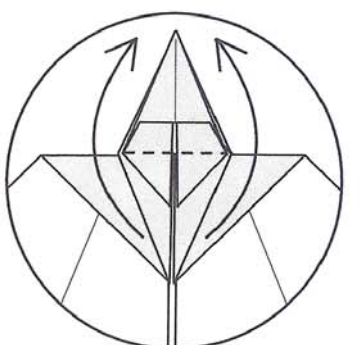

32  
Plier les deux  
pointes vers le haut.

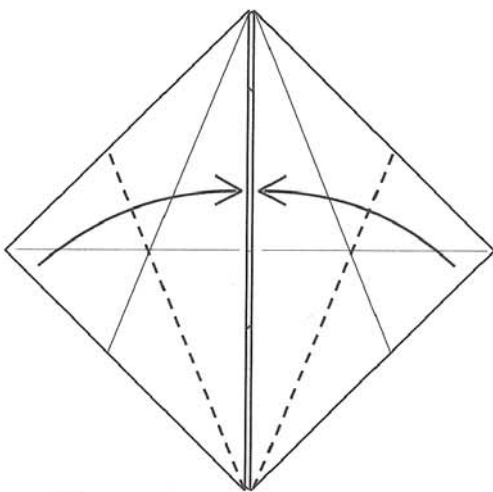

33  
Plis vallées.

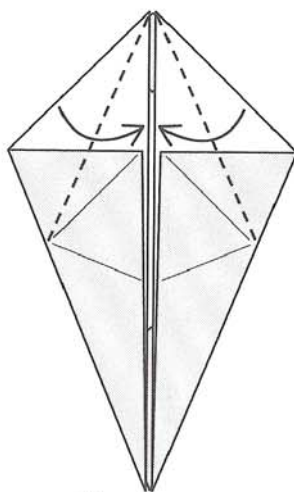

34  
Plis vallées.

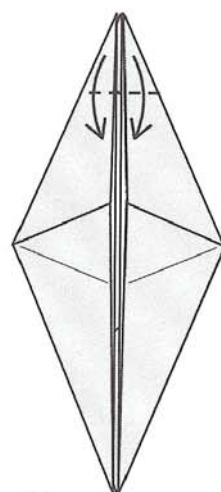

35  
Plier les deux  
pointes vers le bas.

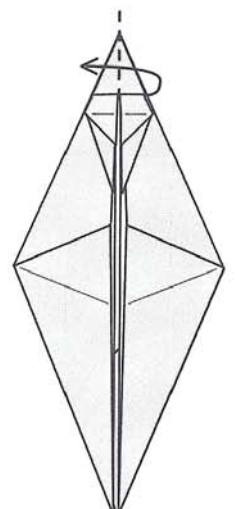

36  
Plier deux volets  
vers la gauche.

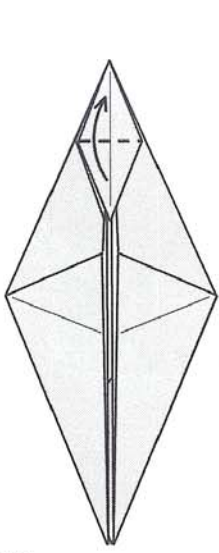

37  
Plier la pointe vers le haut.

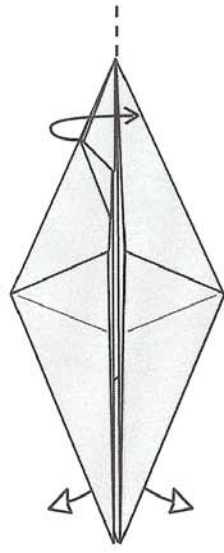

38  
Plier quatre volets vers la droite. Déplier une épaisseur à droite et à gauche sur les pointes du bas.

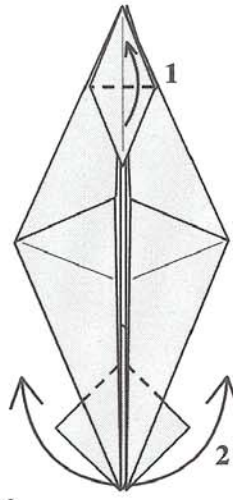

39  
1 Pli vallée .  
2 Ecarter les pointes en bas.

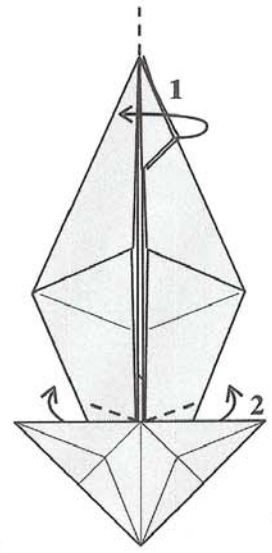

40  
1 Plier deux volets vers la gauche.  
2 Remonter deux épaisseurs pour former les cuisses.

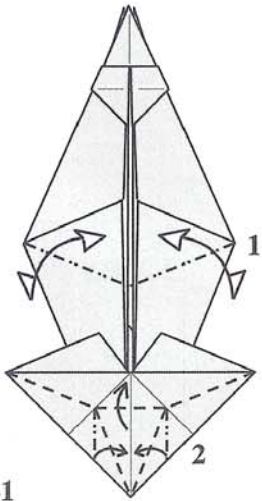

41  
1 Plis montagnes sur toutes les épaisseurs.  
2 Plier la queue.  
Utiliser les marques de plis existantes pour ces deux opérations.

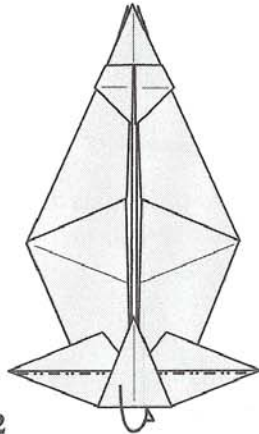

42  
Plis montagnes.

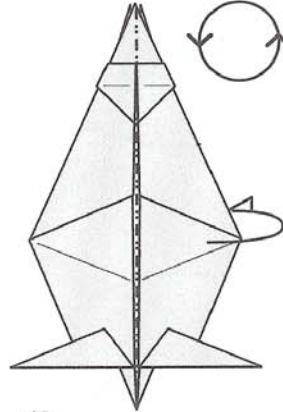

43  
Pli montagne.  
Rotation du modèle.

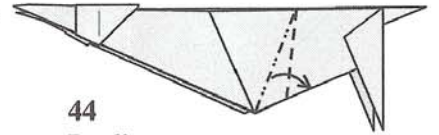

44  
Repli.  
Répéter derrière.

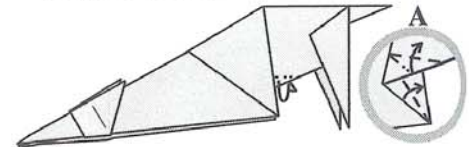

45  
Remonter le ventre.  
Le dessin A montre le pli vu de l'intérieur.

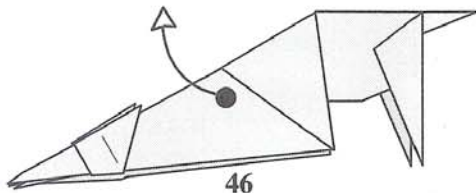

46  
Déplier le repli.

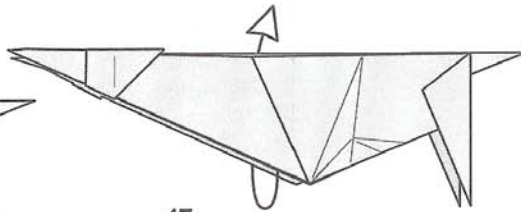

47  
Ouvrir.

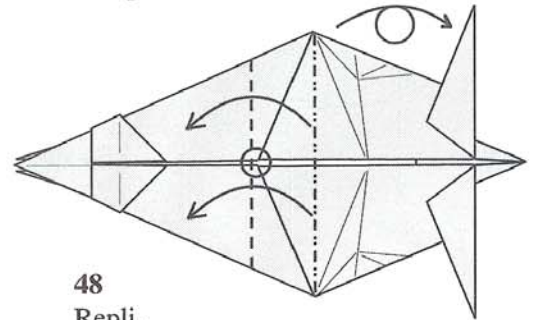

48  
Repli.  
Attention à la position du pli vallée indiquée par le cercle.  
Retourner le modèle.

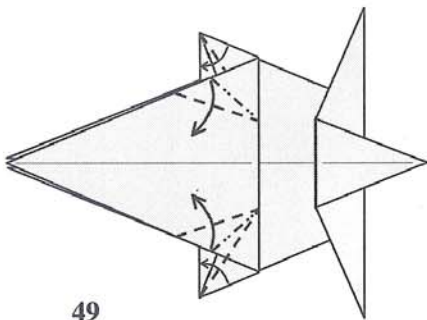

49  
Plis aplatis.

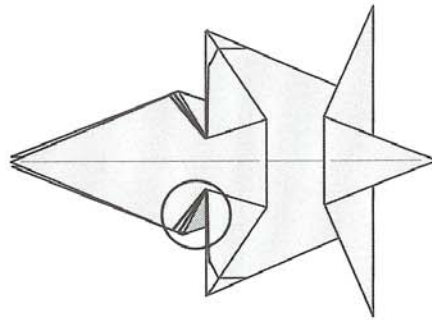

50  
Placer l'épaisseur indiquée en foncé derrière les deux autres épaisseurs.

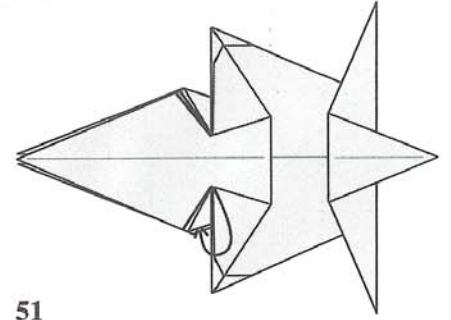

51  
Plier les deux épaisseurs dedans.

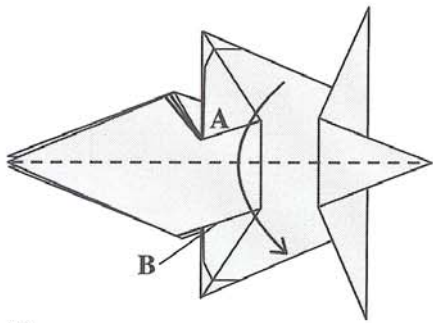

**52**  
Pli vallée.  
A est une languette et B une poche.

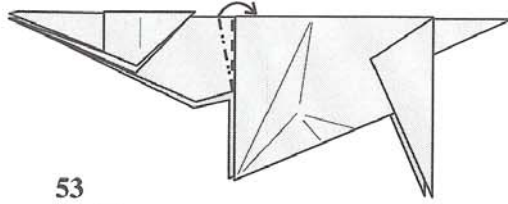

**53**  
Repli.

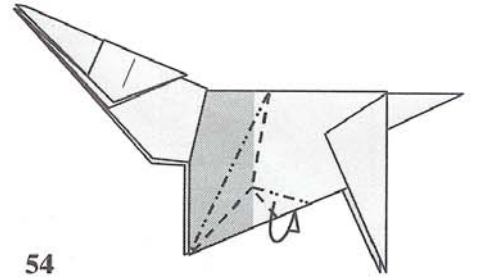

**54**  
Reformer le pli oreille de lapin.  
Glisser le pli devant l'épaisseur intérieure indiquée en foncé.  
Répéter derrière.

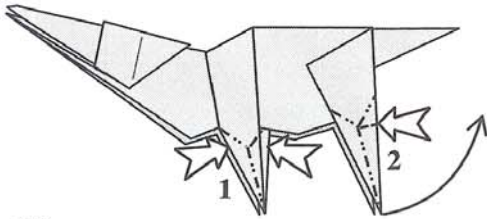

**55**  
1 Pincer la patte avant.  
2 Double oreilles de lapin pour la patte arrière.  
Répéter derrière.

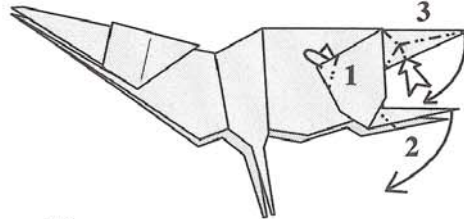

**56**  
1 Pli montagne pour la cuisse.  
2 Pli inversé pour la patte arrière.  
3 Double oreilles de lapin pour la queue.  
Répéter derrière.

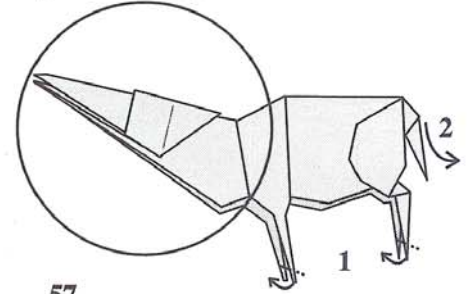

**57**  
1 Former les sabots.  
Répéter derrière.  
2 Courber la queue.  
Sélection de la zone de travail.

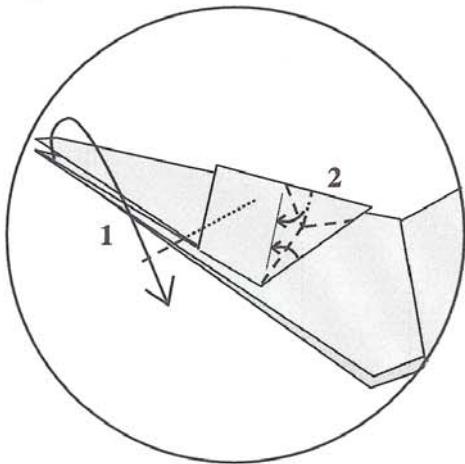

**58**  
1 Pli vallée pour la défense.  
2 Pli oreille de lapin pour l'oreille.  
Répéter derrière.

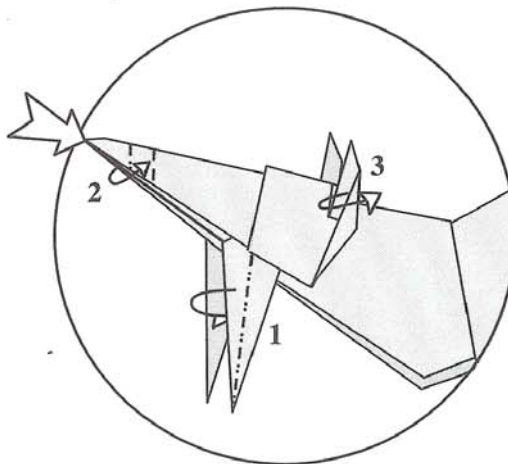

**59**  
1 Pli montagne pour la défense.  
2 Pli étiré pour le groin.  
3 Ouvrir l'oreille.  
Répéter derrière.

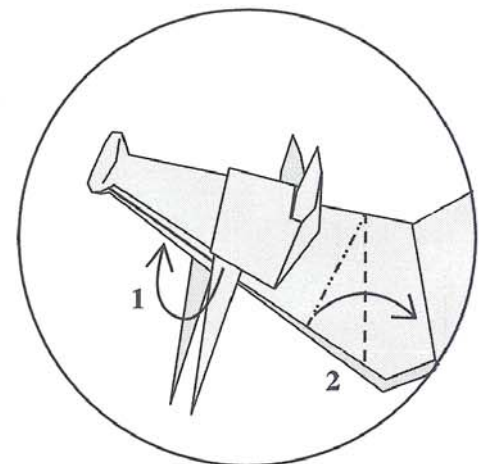

**60**  
1 Courber la défense.  
2 Repli pour le cou.  
Répéter derrière.

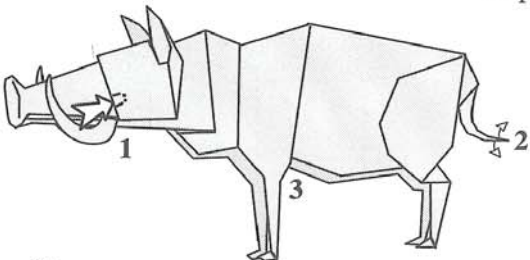

**61**  
1 Former les yeux.  
Répéter derrière.  
2 Ouvrir le bout de la queue.  
3 Insérer A dans B (Cf dessin 52).  
Modelage final.

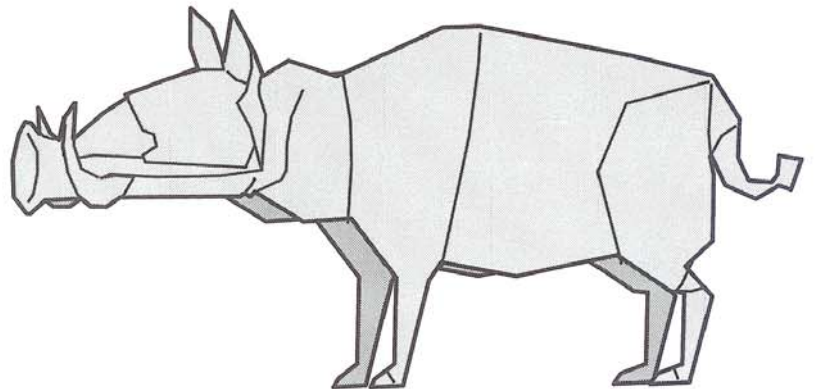

**62**  
PHACOCHERE TERMINE

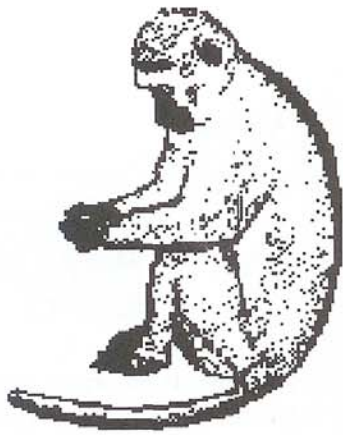

# SINGE

Niveau de difficulté : Intermédiaire

Carré couleur : Recto

Format : 15 cm

Modèle terminé : 7,8 cm

Papier : 80 g

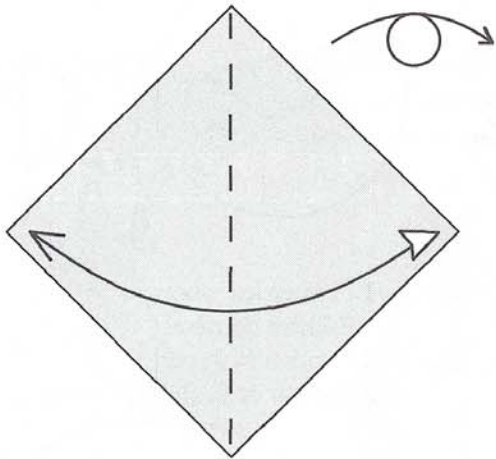

**1**  
Plier et déplier la diagonale.  
Retourner le modèle.

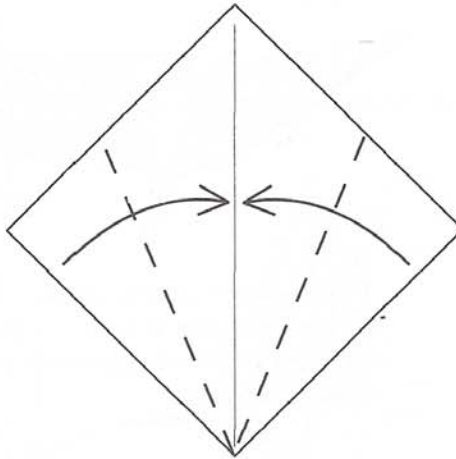

**2**  
Plier les deux côtés sur la diagonale.

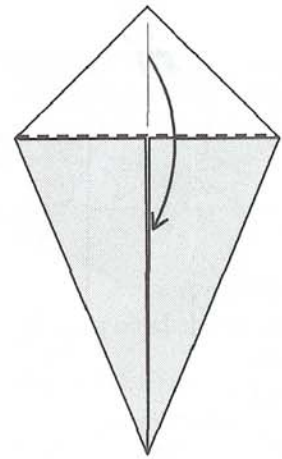

**3**  
Pli vallée.

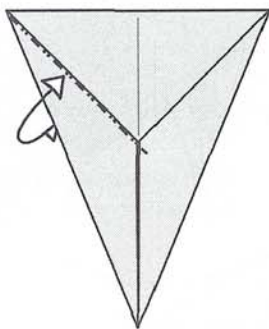

**4**  
Marquer le pli montagne.

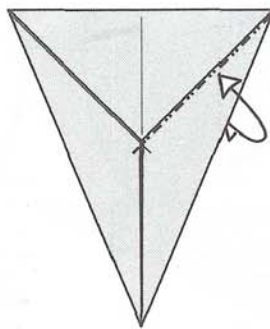

**5**  
Répéter à droite.

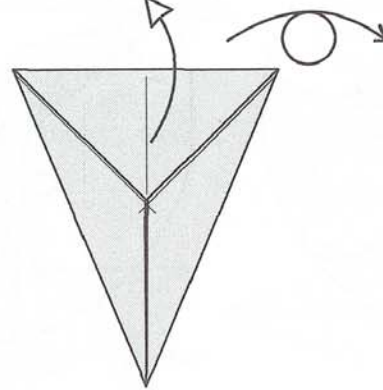

**6**  
Déplier le triangle vers le  
sommet.  
Retourner le modèle.

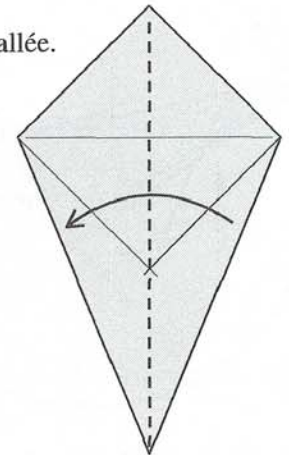

**7**  
Pli vallée.

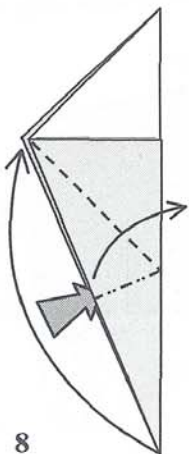

**8**  
Pli aplati.

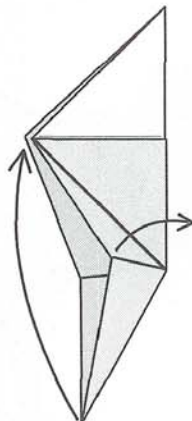

**9**  
Vue 3D du pli aplati.

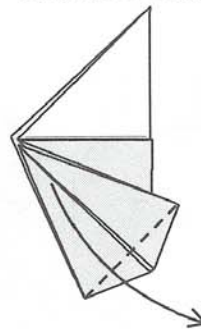

**10**  
Pli vallée.

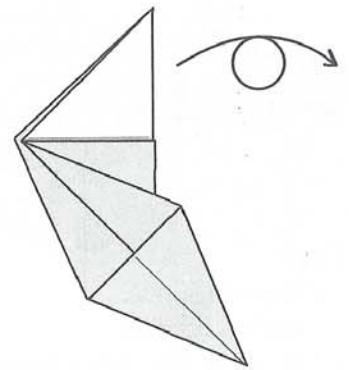

**11**  
Retourner le modèle.

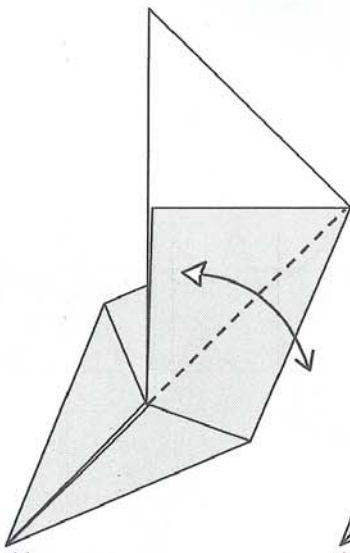

**12**  
Plier, déplier.

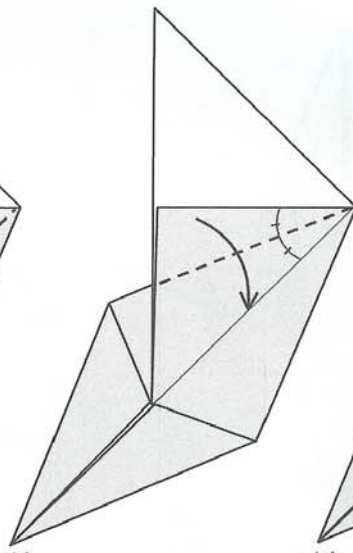

**13**  
Plier toutes les  
épaisseurs à la fois.

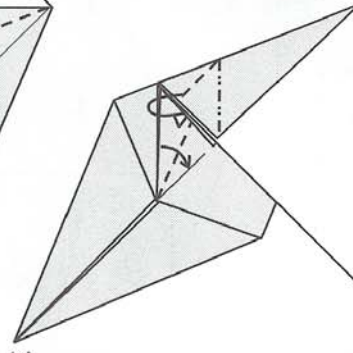

**14**  
Pli oreille de lapin.

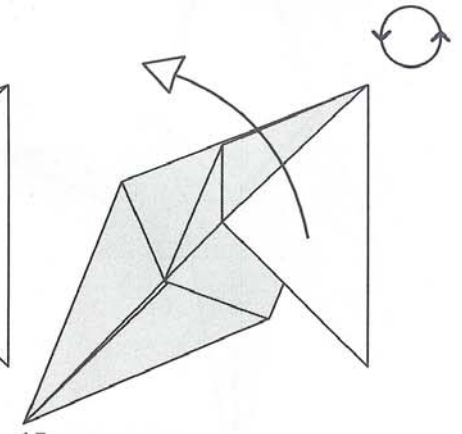

**15**  
Déplier la pointe.  
Rotation du modèle.

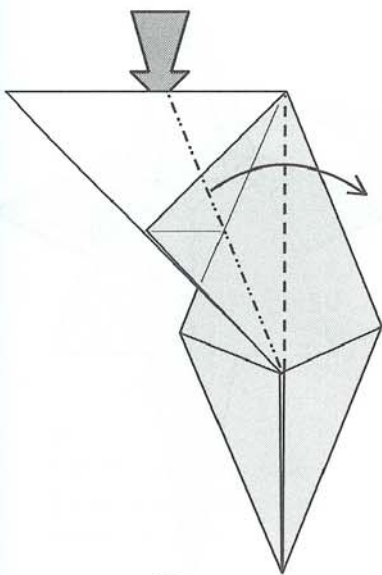

**16**  
Pli aplati.

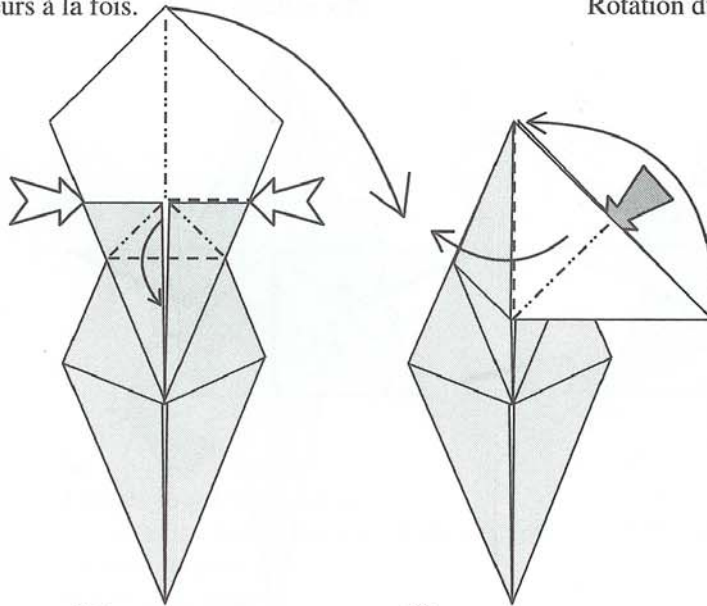

**17**  
Utiliser les marques  
des plis faites en 15 pour  
former ce pli.

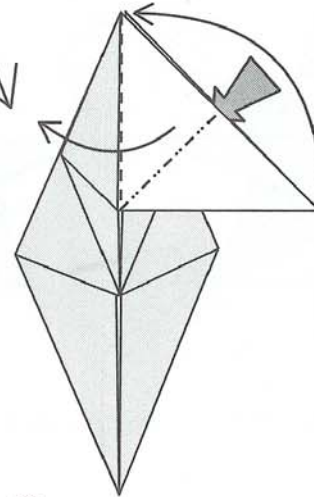

**18**  
Pli aplati.

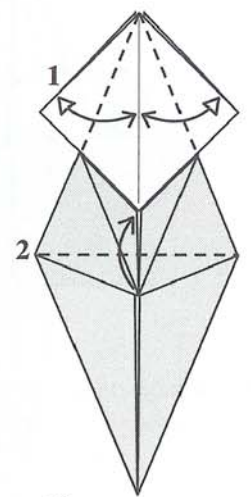

**19**  
1 Plier, déplier.  
2 Pli vallée.

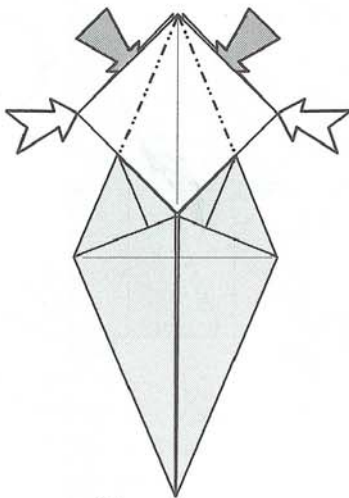

**20**  
Plis inversés.

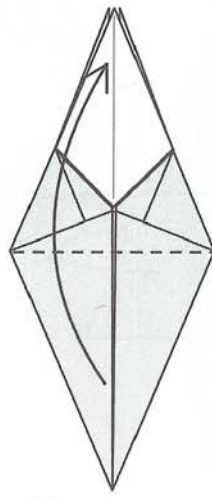

**21**  
Pli vallée.

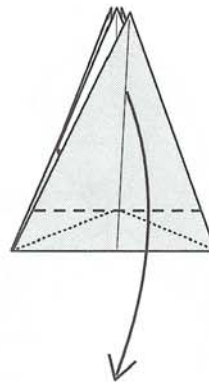

**22**  
Pli vallée.

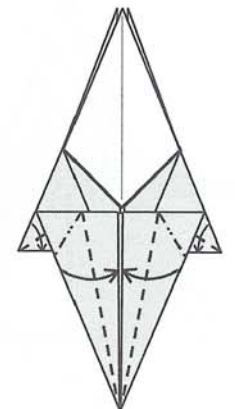

**23**  
Plis pivots.



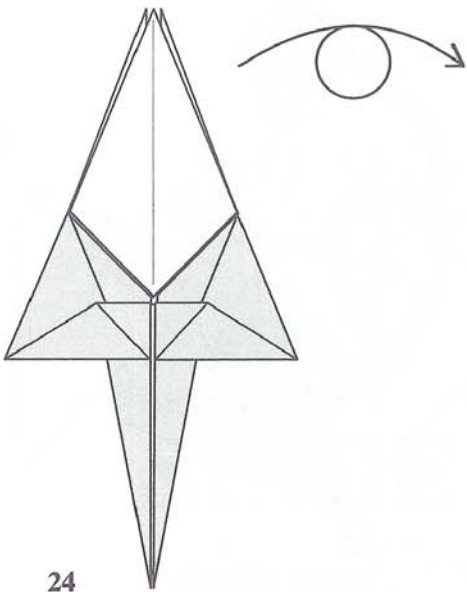

**24**  
Retourner le modèle.

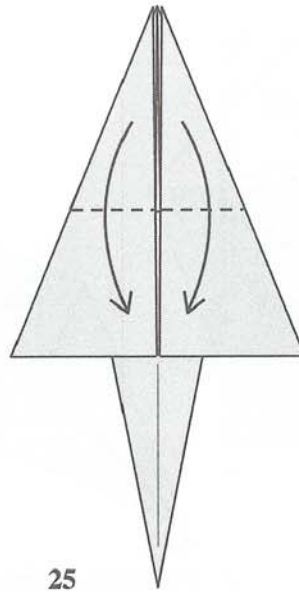

**25**  
Plis vallées.

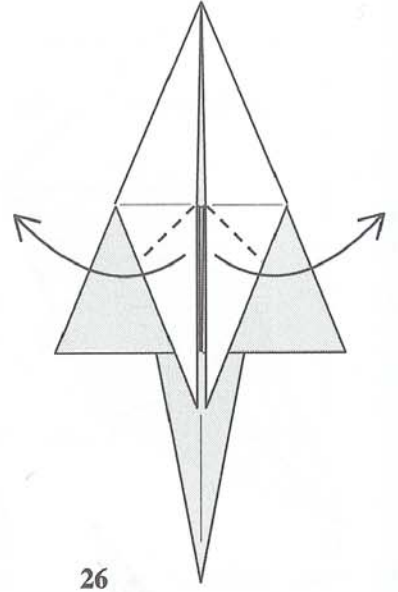

**26**  
Plis vallées.

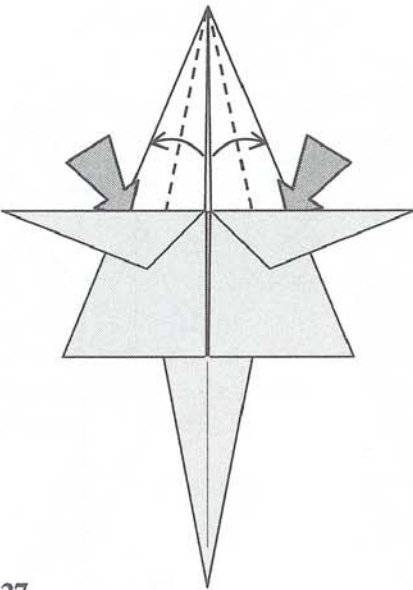

**27**  
Plier la première épaisseur à droite et à gauche.

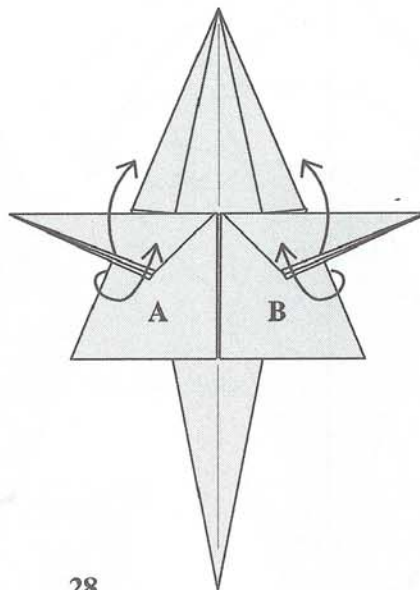

**28**  
Plier la première épaisseur de chaque triangle vers le haut tout en faisant passer les parties A et B dessus.

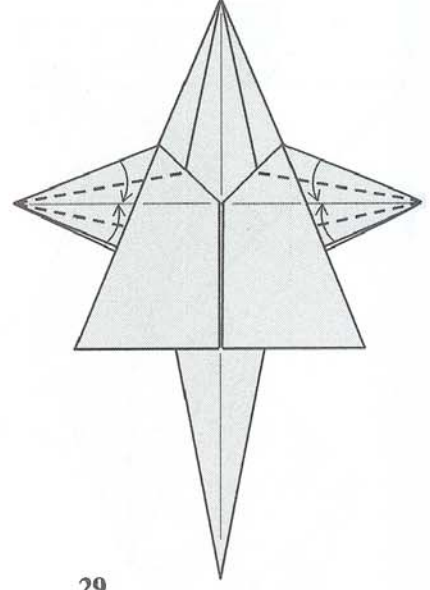

**29**  
Plis vallées.

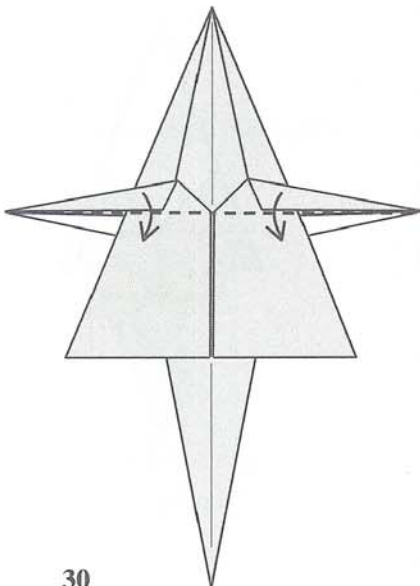

**30**  
Plis vallées.

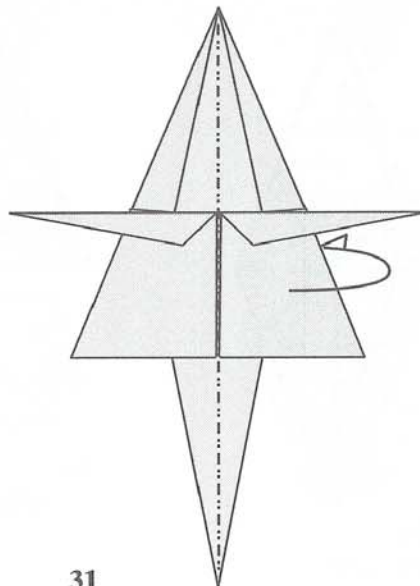

**31**  
Pli montagne.

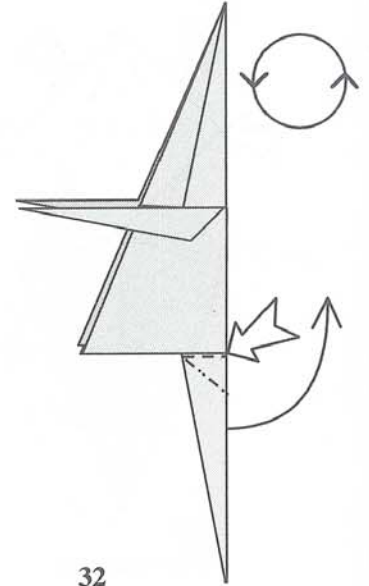

**32**  
Repli pour la queue.  
Rotation du modèle.

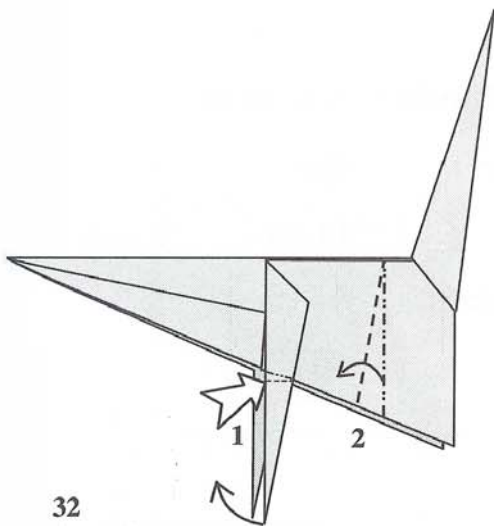

**32**  
**1** Repli pour la patte avant.  
**2** Repli pour former la patte arrière.  
 Répéter derrière.

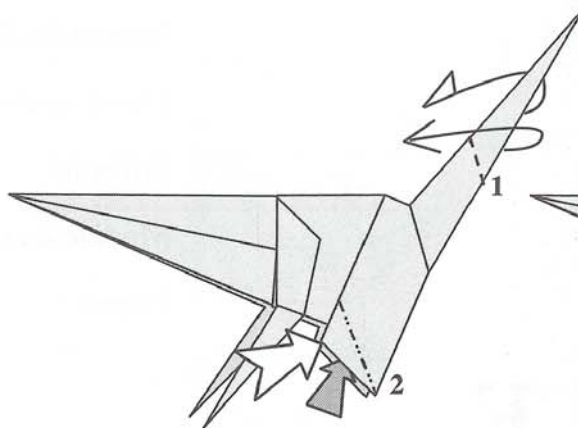

**33**  
**1** Pli inversé extérieur.  
**2** Pli inversé intérieur.  
 Répéter derrière.

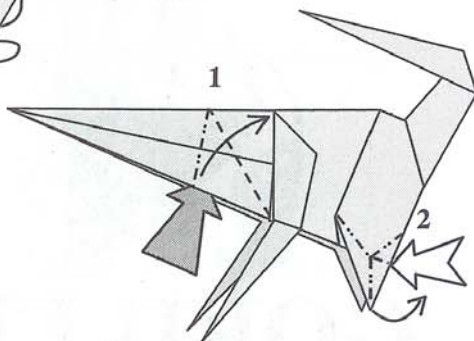

**34**  
**1** Pli aplati  
**2** Double oreilles de lapin.  
 Répéter derrière.

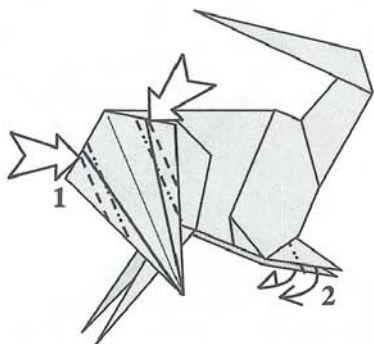

**35**  
**1** Replis pour les oreilles.  
**2** Pli inversé intérieur pour la patte.  
 Répéter derrière.

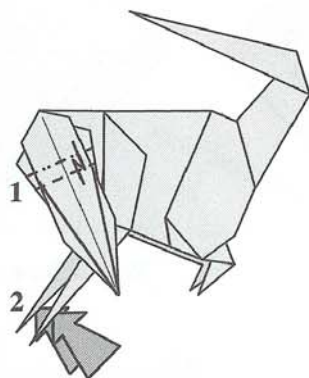

**36**  
**1** Repli pour former les yeux.  
**2** Ecarter les épaisseurs pour former la main.  
 Répéter derrière.  
 Rotation du modèle.

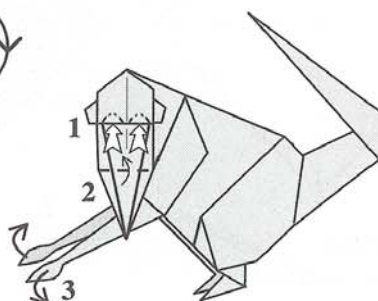

**37**  
**1** Deux enfoncements pour les yeux.  
**2** Pli vallée pour la bouche.  
**3** Articuler les mains.

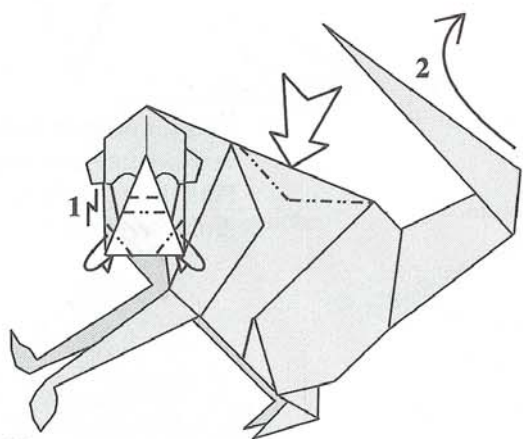

**38**  
**1** Former le visage.  
**2** Courber la queue.  
 Modelage final.

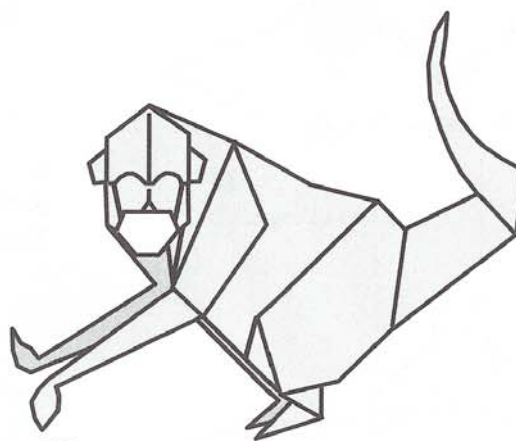

**39**  
**SINGE TERMINE.**



# GORILLE

**Niveau de difficulté :** Complexe

**Carré couleur :** Recto

**Format :** 14 cm

**Modèle terminé :** 4,8 cm

**Papier :** 80 g

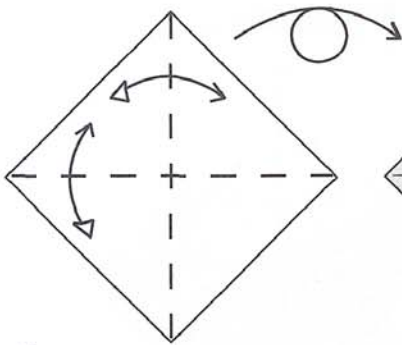

**1**  
Plier, déplier.  
Retourner le modèle.

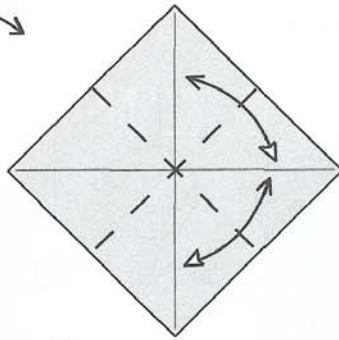

**2**  
Plier, déplier.

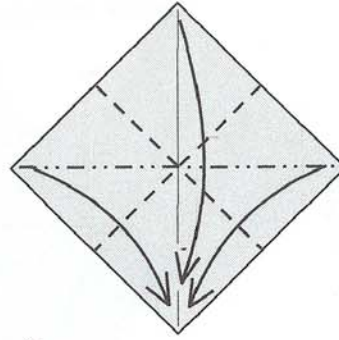

**3**  
Plier la base préliminaire.

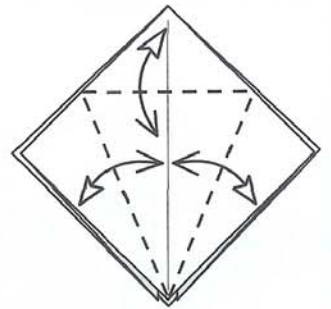

**4**  
Plier, déplier.  
Répéter derrière.

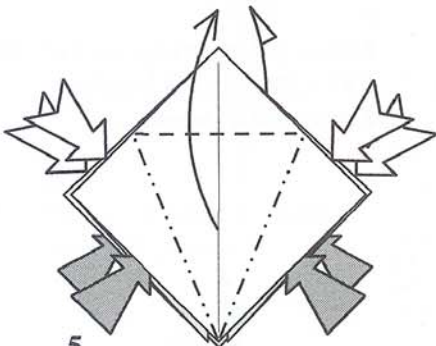

**5**  
Former la base de l'oiseau.

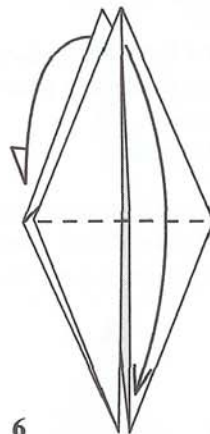

**6**  
Redescendre la pointe.  
Répéter derrière.

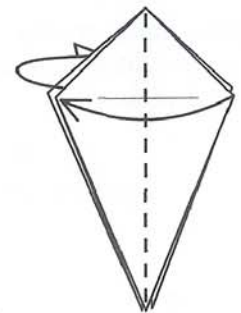

**7**  
Plier un volet de la droite  
vers la gauche devant.  
Plier de la gauche vers la  
droite derrière.

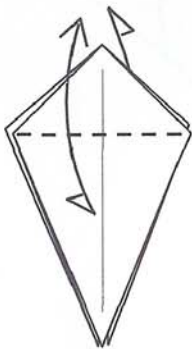

**8**  
Plier, déplier.  
Répéter derrière.

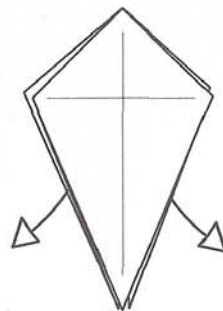

**9**  
Déplier totalement le  
modèle.

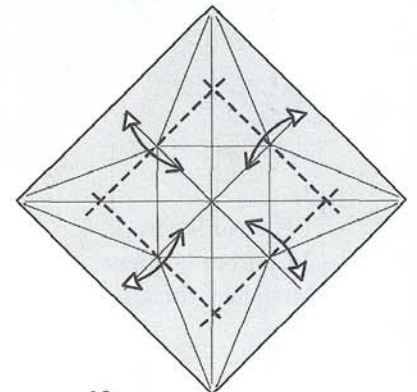

**10**  
Plier et déplier.

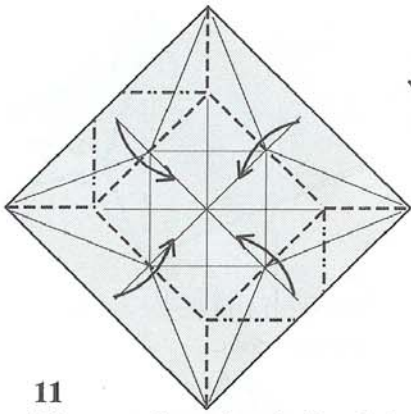

**11**  
Plier en suivant le principe de la base du moulin.  
Rotation du modèle.

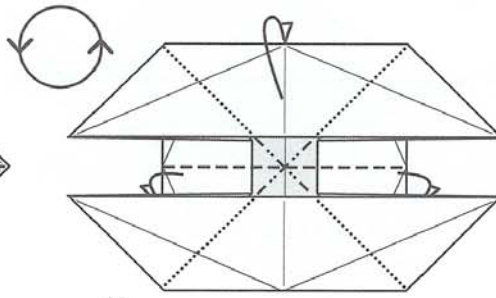

**12**  
Plier la base de la bombe à eau.

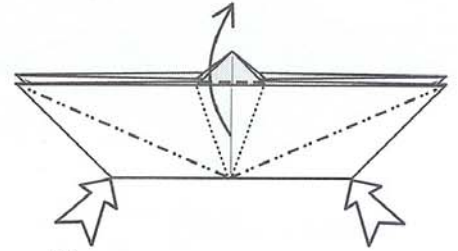

**13**  
Enfoncements étirés sur les deux coins.

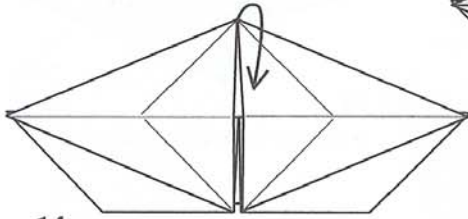

**14**  
Changer la couleur.

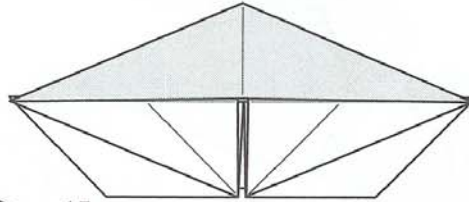

**15**  
Répéter les opérations 13 et 14 derrière.

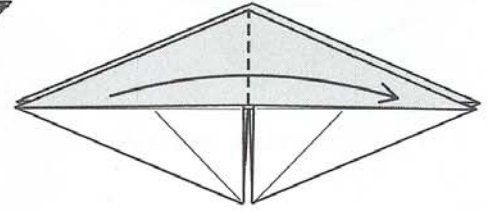

**16**  
Amener la pointe gauche vers la droite.

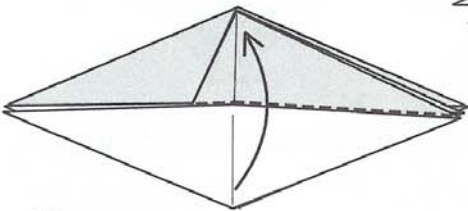

**17**  
Amener un volet vers le haut.

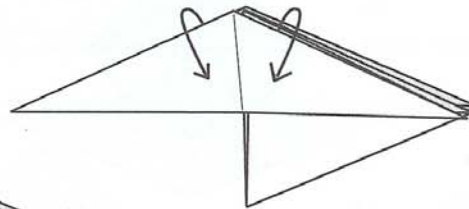

**18**  
Changer la couleur.

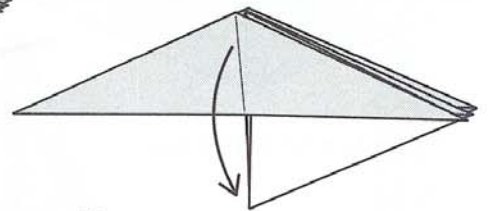

**19**  
Plier le volet vers le bas.

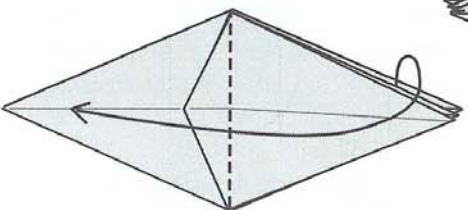

**20**  
Plier deux volets vers la gauche.

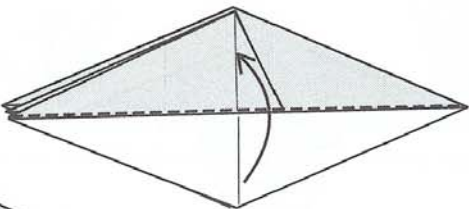

**21**  
Plier le volet vers le haut.

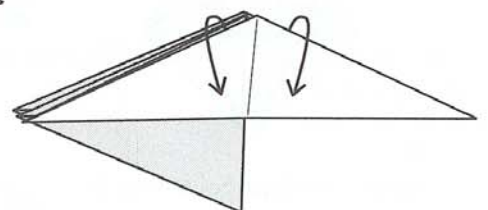

**22**  
Changer la couleur.

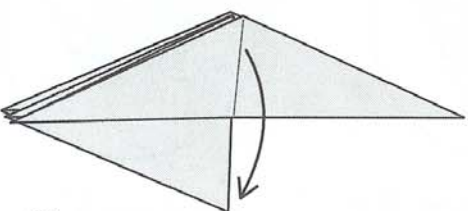

**23**  
Plier le volet vers le bas.

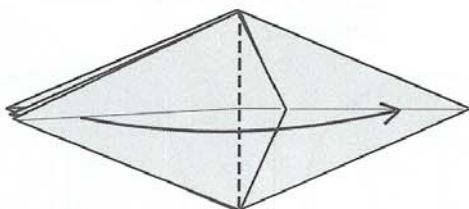

**24**  
Plier la pointe vers la droite.

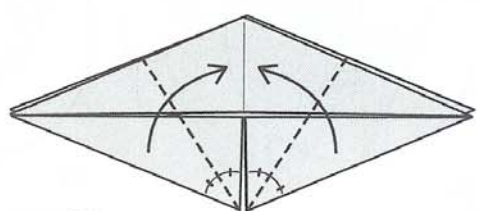

**25**  
Plier les deux bissectrices.

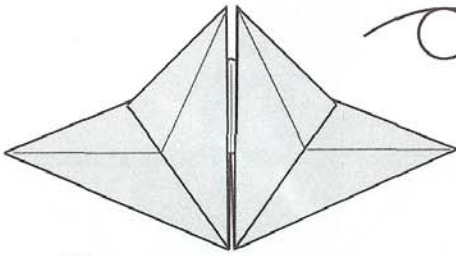

26  
Retourner le modèle.

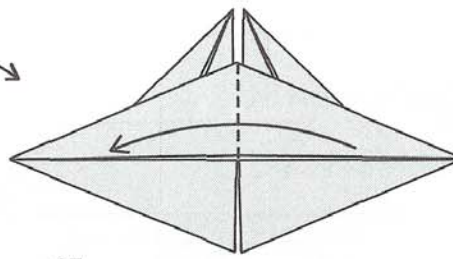

27  
Plier la pointe droite vers la gauche.

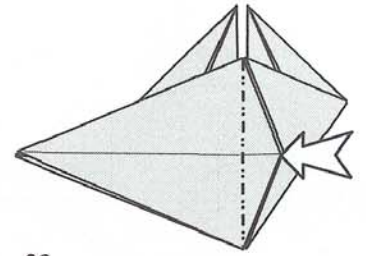

28  
Enfoncement fermé sur le premier coin.

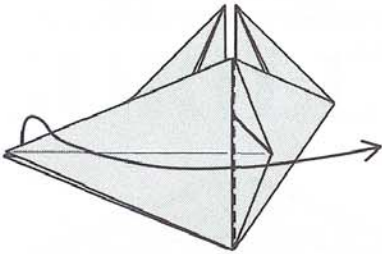

29  
Plier deux volets vers la droite.

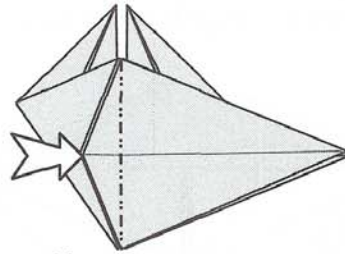

30  
Enfoncement fermé sur le premier coin.

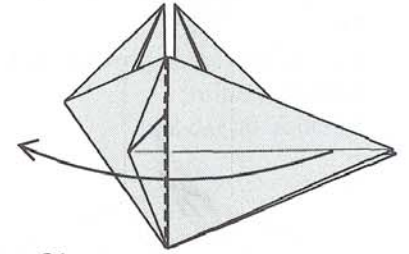

31  
Amener la pointe à droite.

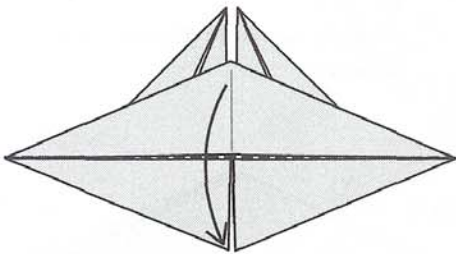

32  
Plier le volet vers le bas.

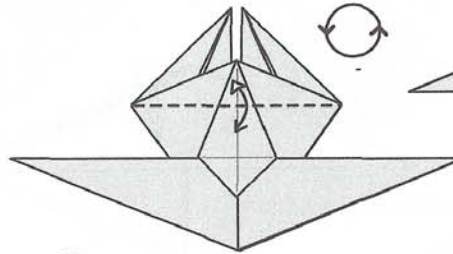

33  
Plier, déplier.  
Rotation du modèle.

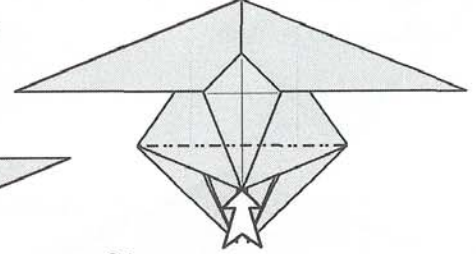

34  
Enfoncement ouvert sur la pointe.

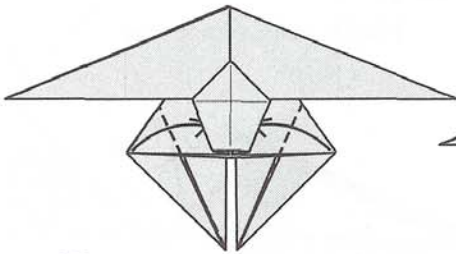

35  
Insérer les deux coins sous le pentagone.

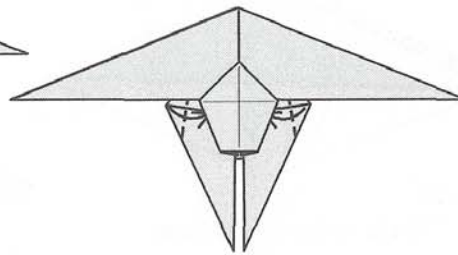

36  
Insérer les deux coins sous le pentagone.

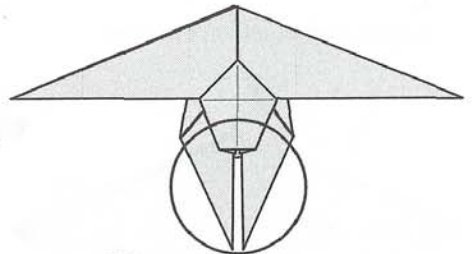

37  
Sélection de la zone de travail.

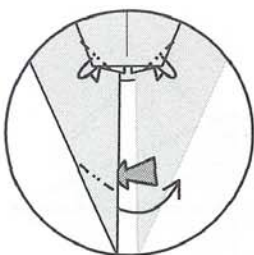

38  
Deux plis montagnes pour le ventre.  
Pli inversé intérieur pour la patte.

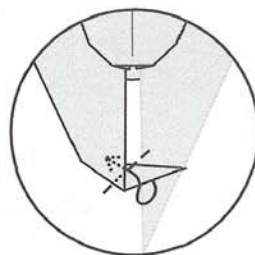

39  
Insérer la pointe dans la patte.

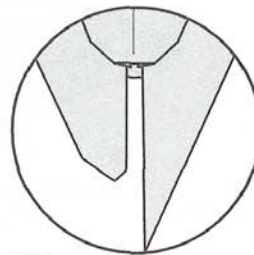

40  
Répéter les étapes 38 et 39 sur l'autre patte.

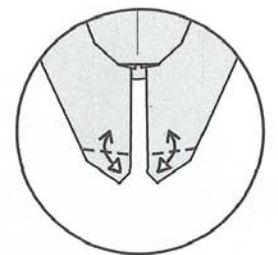

41  
Plier et déplier.  
Repasser à une vue intégrale.

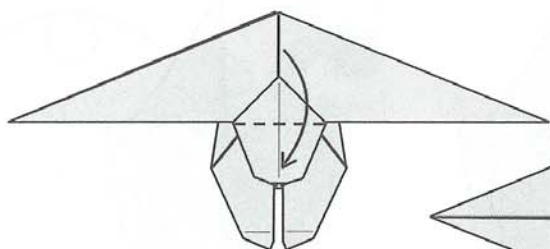

**42**  
Plier le volet vers le bas.

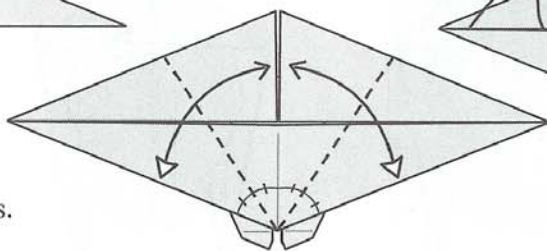

**43**  
Plier, déplier les deux bissectrices.

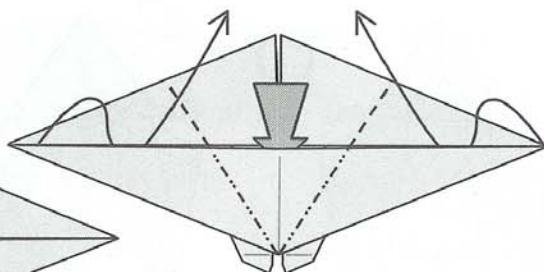

**44**  
Deux plis inversés intérieurs.

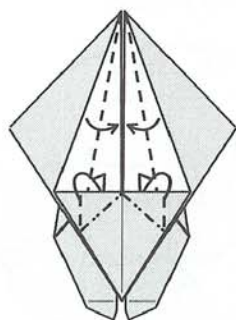

**45**  
Pli pétale.

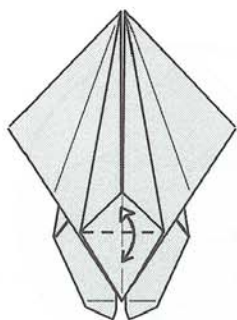

**46**  
Plier, déplier.

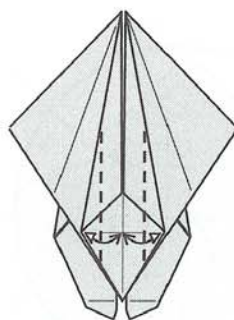

**47**  
Plier, déplier.

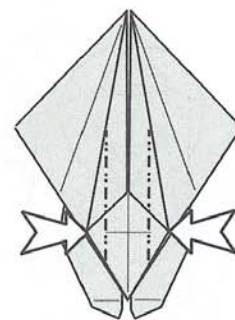

**48**  
Enfoncement ouvert sur les deux coins.

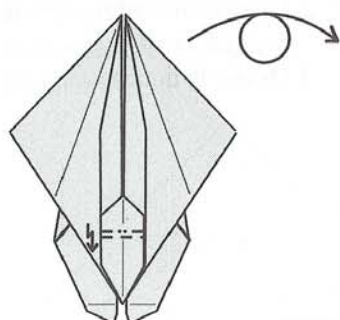

**49**  
Replis pour les yeux.  
Retourner le modèle.

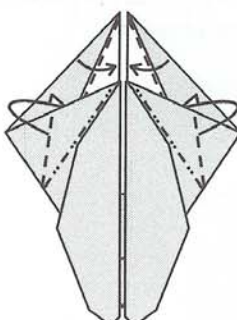

**50**  
Plis inversés intérieurs.

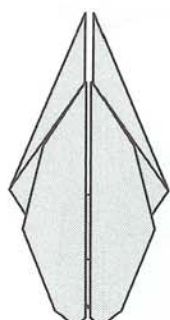

**51**  
Retourner le modèle.



**52**  
Pli montagne pour la tête, pli vallée pour les épaules.

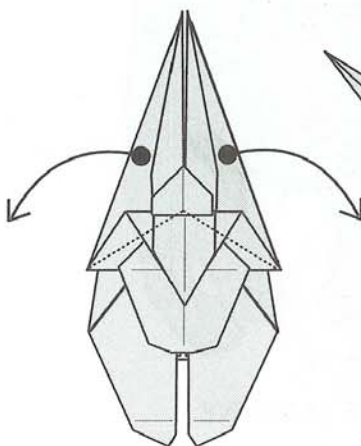

**53**  
Tirer sur chaque bras jusqu'au blocage.

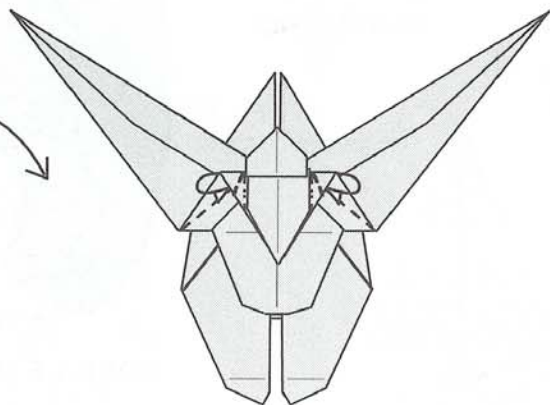

**54**  
Deux plis inversés intérieurs.

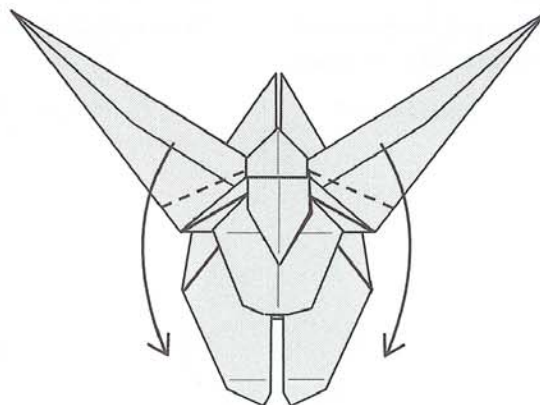

**55**  
Plier les deux bras vers le bas.